

HAKKO 474

DESOLDERING TOOL

吸錫槍

Instruction Manual

使用說明書

日本白光牌

Thank you for purchasing the HAKKO 474 Desoldering Tool.

Please read this manual before operating the HAKKO 474.

Keep this manual readily accessible for reference.

承蒙惠顧，謹致謝忱。

使用 HAKKO 474 之前，請詳閱本使用說明書，正確使用。

閱後請妥為收存，以備日後查閱。

⚠ CAUTION

Remove the pump securing screw (M4×25 marked red) from the bottom of the station. Failure to do so may result in serious problems.

⚠ 注意

使用之前必須除去機身底下的泵拴緊螺絲 (M 4 × 25 紅色記號)，否則可能導致嚴重後果。

Table of Contents (English)



1. Packing List.....	1
2. Specifications.....	1
3. Precautions	2
4. Part Names (Desoldering Gun/Station).....	3
5. Operation (Preparation- Assembly and Connection)	4 • 5
(Desoldering)	5 • 6
(Cleaning during Operation)	7
(Problems during Desoldering) .	7 • 8
(Post-operation Maintenance)	8
(Troubleshooting Guide)	8
6. Maintenance (Desoldering Gun)	9 • 10
(Station)	11
7. Replacement Parts (Replacing Heating Element)	12
8. Parts List (Station).....	13 • 14
(Desoldering Gun)	15
9. Replacement Parts.....	15
10. Wiring.....	16

目錄 (中文)

1. 包裝清單	17
2. 規格	17
3. 安全及使用上的注意事項	18
4. 部件名稱 (吸錫槍 / 控制臺)	19
(準備 --- 裝配和連接)	20 • 21
(吸錫)	21 • 22
(使用時，進行清理工作)	23
(除錫時發生故障)	23
(使用後的保養)	24
(排除故障指南)	24
5. 保養 (吸錫槍)	25 • 26
(控制臺)	27
6. 更換部件	28
7. 部件清單 (控制臺)	29 • 30
(吸錫槍)	31
8. 電路圖	16

1. Packing List Please check to make sure that all the items listed below are included in the HAKKO 474 package.

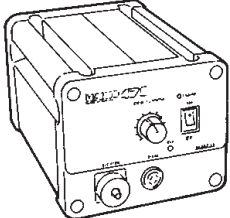
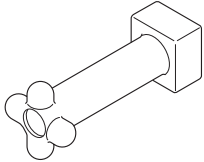
Station	1	Spring Filter	3
Desoldering Gun	1	Cleaning Pin (for ø1.0mm [0.04 in] nozzle)	1
Iron Holder Base	1	Cleaning Pin (for Heating Element)	1
Spring Iron Holder	1	Cleaning Pin Holder	1
Cleaning Sponge	1	Cleaning Drill (for ø1.0mm [0.04 in] nozzle)	1
Filter Pipe	1	Silicone Grease	1
Ceramic Paper Filter (S)	2	Wrench	1
Ceramic Paper Filter (L)	4	Instruction Manual	1

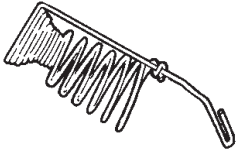
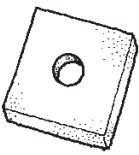
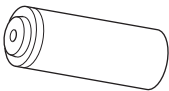
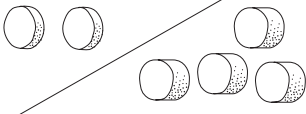
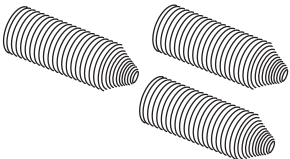
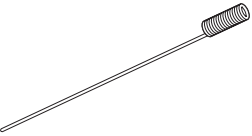
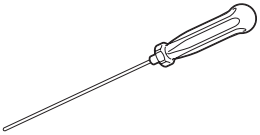
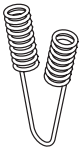
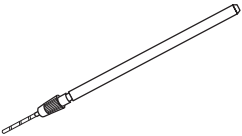
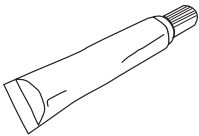
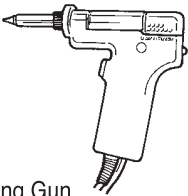
			
Station	Wrench	Iron Holder Base	Spring Iron Holder
			
Cleaning Sponge	Filter Pipe	Ceramic Paper Filter (S) Ceramic Paper Filter (L)	Spring Filter
			
Cleaning Pin for ø1.0mm (0.04 in) Nozzle	Cleaning Pin for Heating Element	Cleaning Pin Holder	Cleaning Drill for ø1.0mm (0.04 in) Nozzle
			
Silicone Grease	Desoldering Gun		

2. Specifications

Name	HAKKO 474
Power consumption	100W

●Station

Part Name	
Output	24V ~
Vacuum generator	Vacuum pump, double cylinder type
Vacuum pressure (max.)	80kpa (600 mm Hg) (24 in. Hg)
Suction flow	15 l/min.
Tip to ground potential	< 2mV (typical 0.6mV)
Tip to ground resistance	< 2Ω
Outer dimension	165(W) × 135(H) × 260(D)mm (6.5 × 5.31 × 10.24 in.)
Weight	3.8kg (8.4lb.)

Condition of measurement

- Insulation resistance
The insulation resistance was measured between the nozzle and the lead of the heating element using a 500 V DC insulation resistance meter.
Caution: The insulation resistance cannot be measured between the nozzle and the power plug as the transformer between the secondary part (heating element) and the primary part acts as an insulator.
- Voltage leakage
The voltage leakage was measured between the nozzle and the grounding plug at a temperature of 480°C (896°F) using an AC mV meter.
Caution: Be sure to ground the unit before measuring the voltage leakage.
- Specifications and design are subject to change without notice.

●Desoldering Gun

Part Name	HAKKO 809
Part No.	C1183
Power consumption	24V – 50W
Temperature range	380 to 480°C (716 to 896°F)
Insulation resistance	> 300MΩ at 420°C (790°F)
Nozzle inside diameter	ø1.0mm (0.04 in.) (nozzle S standard)
Outer dimensions	135(W) × 174(H)mm (5.31 × 6.85 in.)
Weight, less cord	200g (0.44lb.)

NOTE:

- * This product is protected against electrostatic discharge.
- * Specifications and design are subject to change without notice.

3. Precautions

In this instruction manual, "WARNING" and "CAUTIONS" are defined as follows.

WARNING

 **WARNING:** Misuse may potentially cause death of, or serious injury to the user.

 **CAUTION :** Misuse may potentially cause injury to the user or physical damage to the objects involved.

For your own safety, be sure to comply with these precautions.

CAUTION

Remove the pump securing screw (M4×25 marked red) from the bottom of the station.

Failure to do so may result in serious problems.

When the power is on, the nozzle temperature is between 380°C/716°F and 480°C/ 896°F. Since mishandling may lead to burns or fire, be sure to comply with the following precautions.

- Do not touch the metallic parts near the nozzle, nearby plastic parts and the spring iron holder.
- Do not use the product near flammable items.
- Advise other people in the work area that the unit can reach a very high temperature and should be considered potentially dangerous.
- Turn the power off while taking breaks and when finished using the unit.
- Before replacing parts or storing the unit, turn the power off and allow the unit to cool to room temperature.

To prevent damage to the unit and ensure a safe working environment, be sure to comply with the following precautions.

- Do not use the unit for applications other than desoldering.
- Do not rap the desoldering gun against the work bench to shake off residual solder, or otherwise subject the iron to severe shocks.
- Do not modify the unit.
- Use only genuine HAKKO replacement parts.
- Do not wet the unit or use the unit when your hands are wet.
- Set the ceramic paper filter (S) for the filter retainer (station), and the ceramic paper filter (L) for the filter pipe (gun).
- Maintain the desoldering gun and the station.
- While using the unit, don't do anything which may cause bodily harm or physical damage.

CAUTION:

This product includes such features as electrically conductive plastic parts and grounding of the handpiece and station as measures to protect the device to be soldered from the effects of static electricity. Be sure to observe the following instructions:

1. The handle and other plastic parts are not insulators, they are conductors. When replacing parts or repairing, take sufficient care not to expose live electrical parts or damage insulation materials.
2. Be sure to ground the unit during use.

4. Part Names (Refer to p.19, 20 & 21 for part nos.)

English

● Desoldering Gun

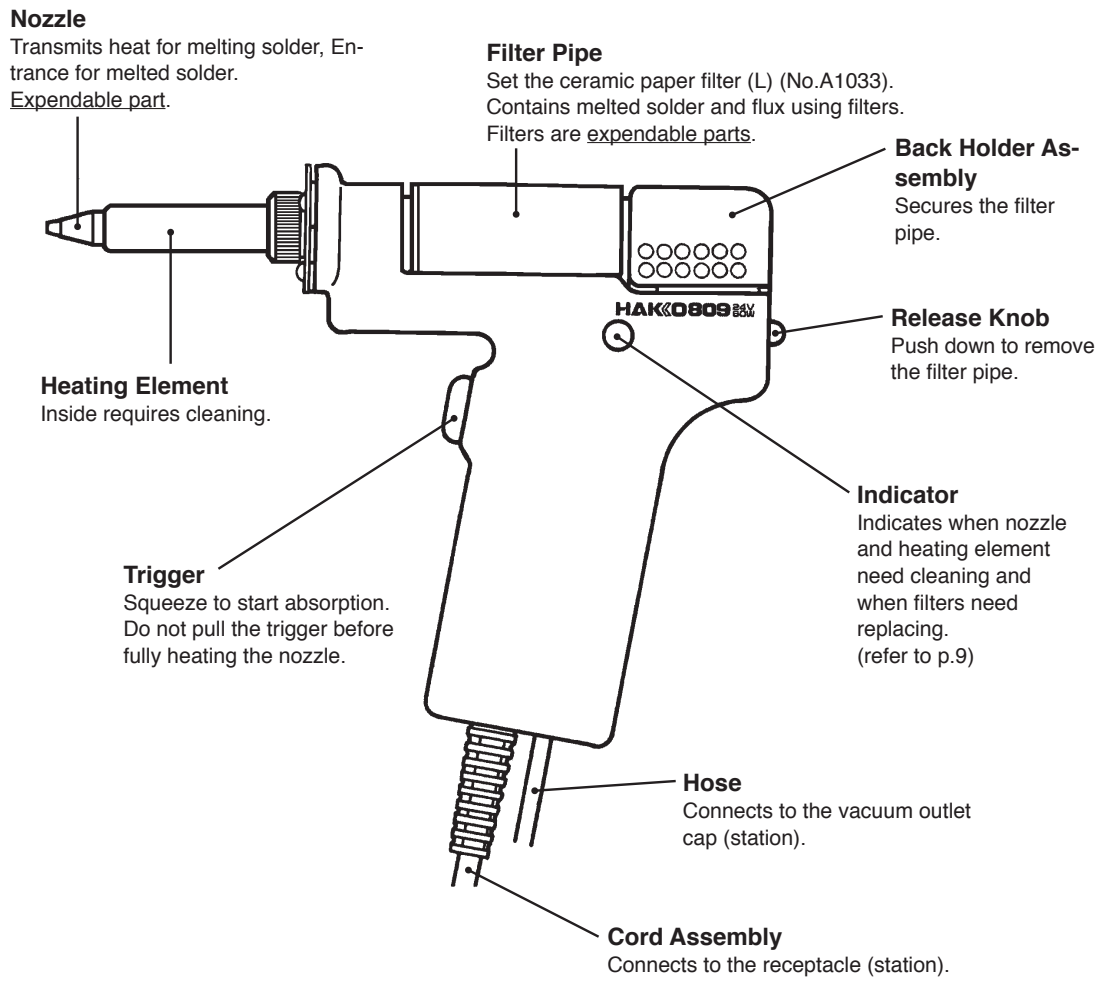

● Station

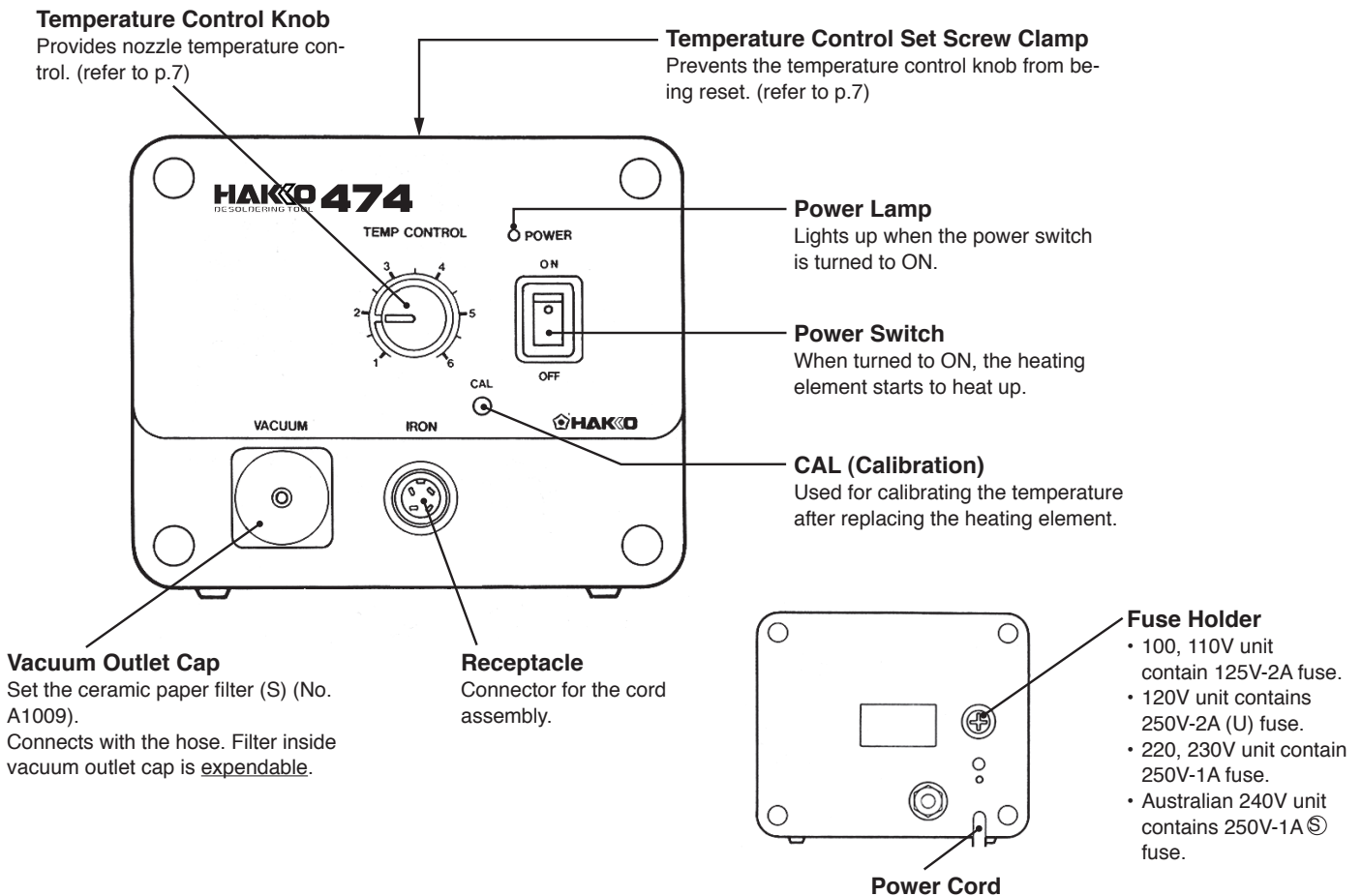

5. Operation

Preparation-Assembly and Connection

Assemble the HAKKO 474 on a flat surface.

1. Remove the pump securing screw (M4 × 25 marked red) from the bottom of the station.

2. Assemble the iron holder.

- Set the spring iron holder and cleaning pin holder in the iron holder base.
- Dampen the cleaning sponge with water and then squeeze it dry.

CAUTION
 The sponge is compressed. It will swell when moistened with water. Be sure to dampen the sponge with water before use. Be sure to remove the round portion of the sponge.

3. Insert the desoldering gun and cleaning pins.

- Fully insert the desoldering gun into the spring iron holder.

CAUTION
 The spring iron holder becomes extremely hot during operation of the desoldering gun. Do not touch the spring iron holder during and immediately after using the gun.

4. Connections

CAUTION
 Be sure to turn off the power switch before connecting or disconnecting the cord assembly and the power plug. Failure to do so may damage the P.W.B.

- Connect the cord assembly to the receptacle (marked "IRON").
- Connect the hose to the vacuum outlet cap (marked "VACUUM").

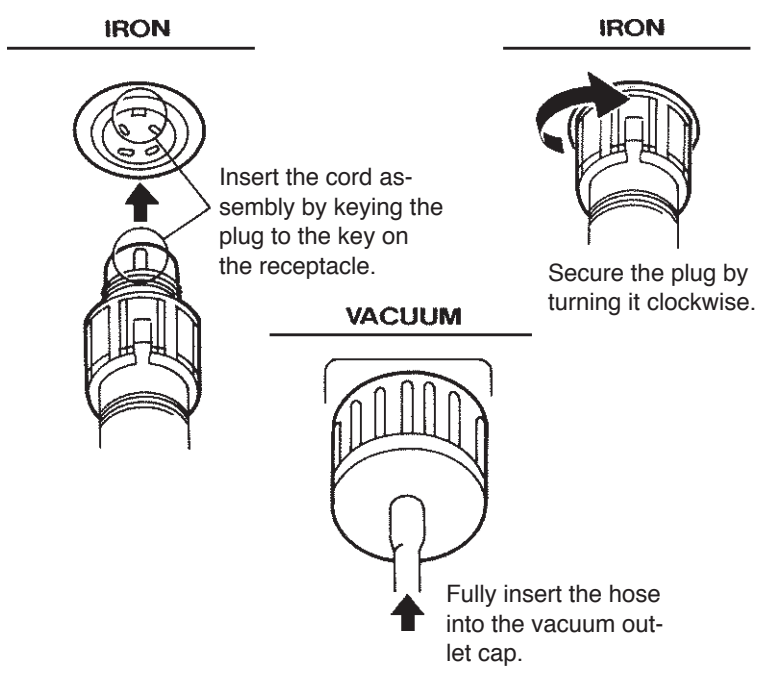
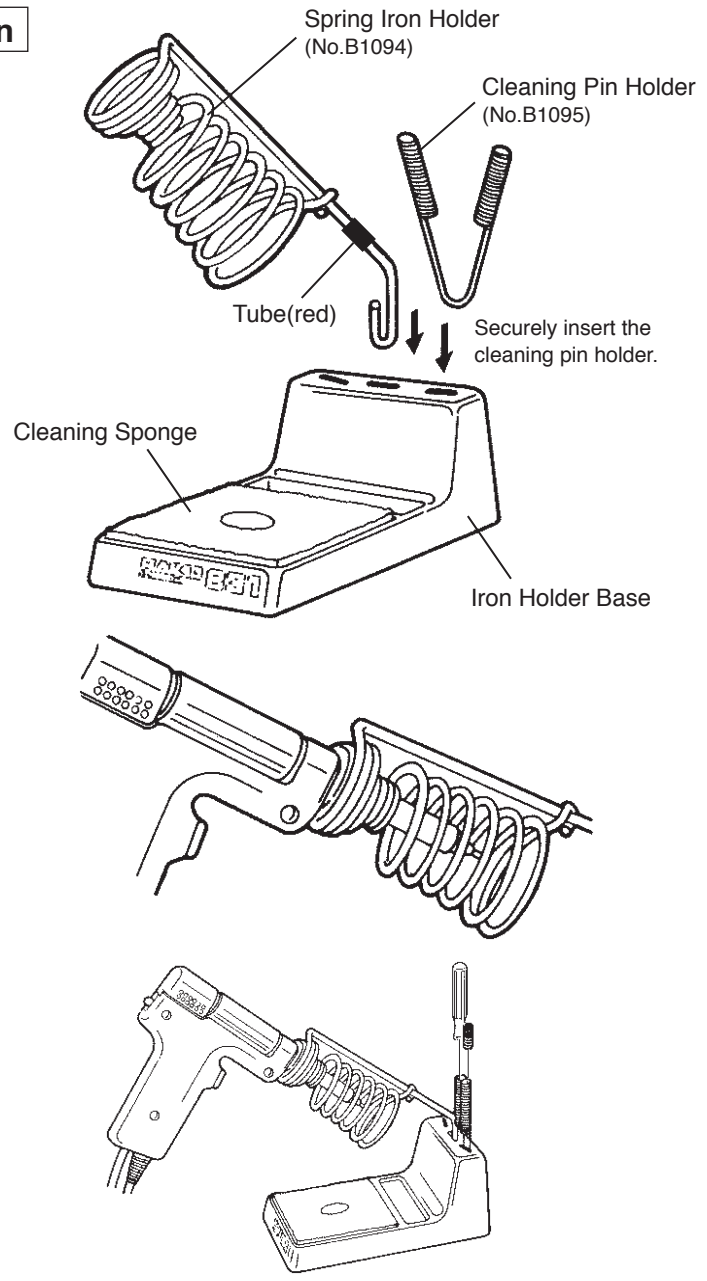

5. Operation

5. Power switch

- Confirm that the power switch is set in the OFF position, then connect the power plug to the power source.

CAUTION
The entire unit is constructed of conductive materials. Always ground the unit.

- Turn the power switch to ON. The power lamp should light up.
- The nozzle begins to heat up as soon as the power switch is turned to ON.

6. After turning the power switch to ON, wait 3 minutes before beginning desoldering operations.

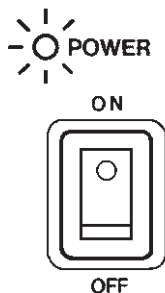

The power lamp lights up.



The nozzle heats up.

The power lamp doesn't light up.

1. Is the power cord properly connected?
2. Is the fuse blown?

The nozzle doesn't heat up.

1. Is the cord assembly properly connected?
2. Is the heating element broken?

CAUTION : The desoldering gun must be placed in the iron holder when not in use.

Desoldering

After turning the power switch to ON, wait 3 minutes before beginning desoldering operations.

1. Set the temperature.

CAUTION
Always set the temperature to as low as possible for the work being done.

- To more precisely set the temperature, measure the temperature at the nozzle using a soldering iron thermometer and adjust the temperature control knob accordingly.

We recommend the HAKKO 191 thermometer or HAKKO 192 soldering tester for measuring the nozzle temperature.

- The temperature control knob can be secured by tightening the temperature control set screw clamp ("+" screw) at the top of the HAKKO 474 unit.

The temperature can be adjusted between 380°C (716°F) and 480°C (896°F) with temperature control knob.

Please refer to the chart below, and adjust the temperature control knob.

knob	P.W.B.
1 and 2	Single-sided P.W.B.
3 and 4	Through-hole P.W.B.
5 and 6	Multilayer P.W.B.

CAUTION
Never insert the cleaning pin in the hole of temp. control set screw clamp. As this may result in damage to the unit.

Lock
Unlock

Secure the temperature control set screw clamp with a cross point screwdriver.

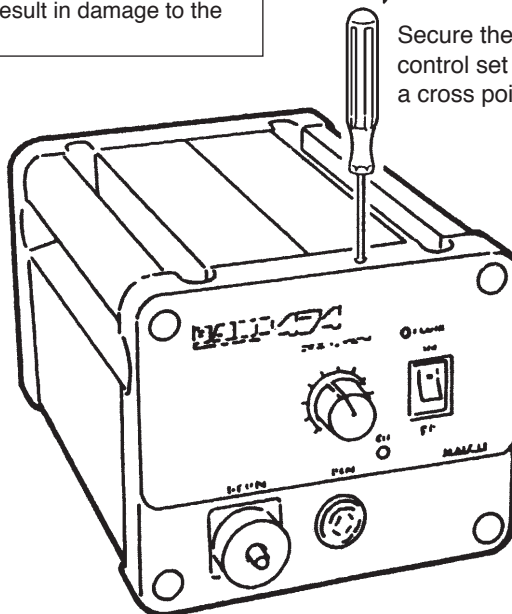

2. Clean the tip of the nozzle.

- Keep the solder-plated section of the nozzle a shiny white by coating it with a small amount of solder.

If the tip of the nozzle is coated with oxide, the nozzle's heat conductivity will be lowered.

Coating the tip with a small amount of fresh solder ensure maximum heat conductivity.

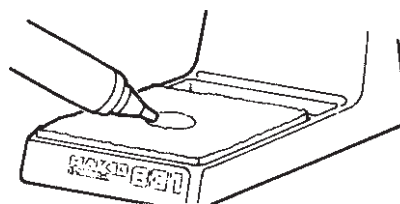

Wipe away any oxide or old solder from the nozzle using the hole in the center of the sponge.

3. Melt the solder.

- Apply the nozzle to the soldered part and melt the solder.

⚠ CAUTION

Never allow the nozzle to touch the board itself.

- Confirm that the solder is melted.

⚠ CAUTION

To confirm that all solder is melted, observe the inside of the hole and the backside of the P.W.B. If this is difficult to do, try slowly moving the lead with the nozzle – If the lead moves, the solder is melted.

⚠ CAUTION

Never move the lead by force. If it doesn't move easily, the solder isn't yet fully melted.

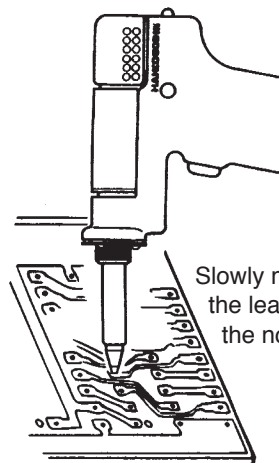
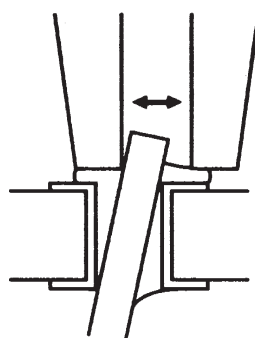
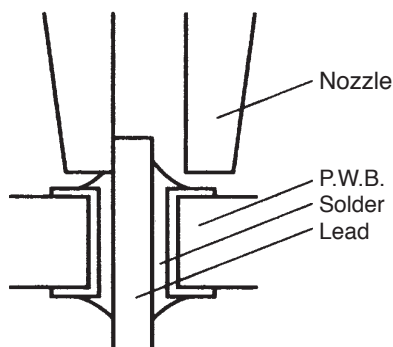

4. Absorb the solder.

- After confirming that the solder is completely melted, absorb the solder by squeezing the trigger on the gun.

⚠ CAUTION

Never leave any solder remaining inside the hole in the P.W.B.

- After fully absorbing all the solder, cool the soldering junction in order to prevent it from becoming resoldered.

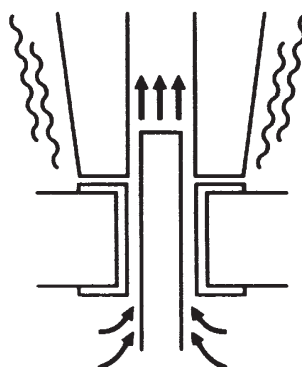

Absorb the solder by slowly moving the lead back and forth with the tip of the nozzle.

5. Problems during desoldering.

- If solder remains, resolder the component and repeat the desoldering process.

5. Operation

Heated solder and flux can cause oxides to form and adhere to the nozzle and the inside of the heating element. These oxides not only lower the heat conductivity, but can also clog the nozzle and heating element, resulting in a drop in suction efficiency. Should there be a noticeable drop in suction efficiency during operation, replace the filter and clean the nozzle and heating element with the provided cleaning pin.

Cleaning during Operation

1. Observing the indicator



While looking at the indicator and with the hole of the nozzle open, pull the trigger and look at the indicator. If it is red, clean the nozzle and heating element, empty the filter pipe, and replace the filters. If the indicator is blue, cleaning is not necessary and operations can be resumed.

CAUTION
The indicator will not operate accurately if the hole of the nozzle is closed or if the solder in the hole of the P.W.B. is not melted.

CAUTION
The indicator on the HAKKO 475 reads in a different way.
For instruction on the reading the HAKKO 475 indicator, please refer to the HAKKO 475 instruction manual.

2. Replacing the filter

Replace the filter as shown 1 to 3. During operation, the filter pipe is very hot. Wait until the filter pipe is cool before replacing the filter. We recommend keeping a second filter pipe containing new filters handy, and replacing the installed filter pipe with this backup filter pipe.

Normal	Abnormal	Solution
		If the indicator is more than half red, replace the filter and clean the nozzle and the inside of the heating element. (refer to p.12 Maintenance of the Desoldering Gun)
Blue or slight amount of red can be seen.	More than half of the indicator is red.	

CAUTION : If there is a noticeable drop in suction efficiency, clean the nozzle and heating element with the cleaning pin.

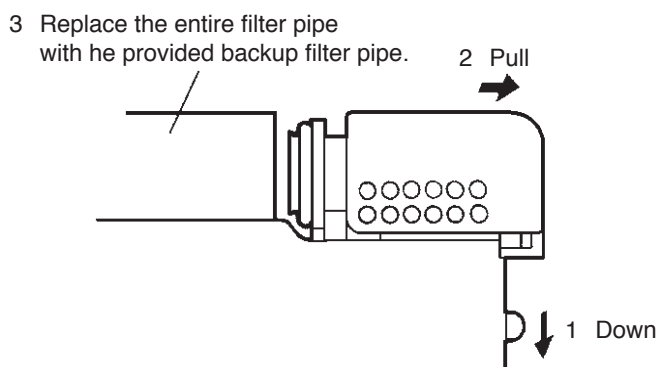

Problems during Desoldering

- A. The solder in the junction is not sufficiently melted.
- B. Suction power is dropping.

A. The solder in the junction is not sufficiently melted.

● Temperature is not high enough

The following parts require a greater heat capacity to desolder.

- Multilayer P.W.B.s, power supplies, ground planes in through-hole P.W.B.s, high-capacity transistors, triacs with heat radiation fins, tuner P.W.B. ground wires, and large-scale transformer terminals.

Use a preheating oven or heating gun to heat the P.W.B. to a temperature that won't damage the board or its components [between 70°C (160°F) and 80°C (180 °F)], then desolder. Do not increase the temperature of the gun by recalibration as this may damage the P.W.B. and its components.

● Nozzle is worn out.

- When the nozzle begins to wear out, the heating efficiency begins to decline. Check the nozzle. If the solder plating is damaged, or the nozzle is eroded, replace the nozzle. (refer to p.9)

B. Suction power is dropping.

- Replace the filters, and clean the nozzle and the inside of the heating element, (refer to p.12 to p.16, Maintenance of Desoldering Gun and Station)

- **Air is leaking from the vacuum system.**

Air leakage cannot be determined from the indicator.

Check the air-tightness of the following parts and replace any that are worn.

- | | |
|--|------------------------------|
| a. Contact point of the nozzle and heating element | c. O-ring in the back holder |
| b. Front holder and nearby parts | d. Hose |
| | e. Vacuum outlet cap |
| | f. Packing and nearby parts |

Post-operation Maintenance

To ensure a long service life, always perform the following maintenance procedures immediately after using the HAKKO 474 unit.

- Remove all solder from the inside of the nozzle and heating element.
- Clean the tip of the nozzle with the cleaning sponge, then coat the tip with a fresh layer of solder to protect the solder plating.

Troubleshooting Guide

⚠ WARNING : If the power cord is damaged, it must be replaced by the manufacturer, its service agent or similarity qualified person in order to avoid personal injury or damage to the unit.

- **Power lamp does not light up.**

- Is the power cord plugged in correctly.
Securely insert the power cord into the power supply.
- Is the fuse blown?
Determine why the fuse blew and eliminate the cause, then replace the fuse.
Example Is the inside of the gun short-circuited?

- **Pump does not operate.**

- Is the cord assembly properly connected?
Reconnect the cord assembly. (refer to p.4)
- Is the nozzle or hole in the heating element clogged?
Clean it. (refer to p.9)

- **Solder is not being absorbed.**

- Is the spring filter full of solder?
Replace it with a new one. (refer to p.10)
- Is the ceramic filter hardened?
Replace it with a new one .
- Is there a vacuum leak?
Check the connections and replace any worn parts. (refer to p.8)

- **The nozzle does not heat up.**

- Is the desoldering gun cord assembly properly connected?
Reconnect it. (refer to p.4)
- Is the heating element damaged?
Replace it. (refer to p.12)

NOTE : When repairs are needed, please send both the desoldering gun and the station to your sales agent.

6. Maintenance (Desoldering Gun)

English

Properly maintained, the HAKKO 474 desoldering gun should provide years of good service. Efficient desoldering depends upon the temperature, and the quality and quantity of the solder and flux. Perform the following service procedures as dictated by the conditions of the gun's usage.

⚠ WARNING : Since the desoldering gun can reach a very high temperature, please work carefully. Except when cleaning the nozzle and heating element, always turn the power switch off and disconnect the power plug before performing any maintenance procedure.

Servicing the Desoldering Gun

⚠ CAUTION
The desoldering gun will be extremely hot. During maintenance, please wear gloves and work carefully.

1. Inspect and clean the nozzle.

- Plug in the power cord, turn the power switch On and let the nozzle heat up.
- Clean out the hole of the nozzle with the nozzle cleaning pin.

⚠ CAUTION
The cleaning pin will not pass through the nozzle until the solder inside the nozzle is completely melted.

- If the cleaning pin does not pass through the hole in the nozzle, clean with the cleaning drill.
- Check the condition of the solder plating on the tip of the nozzle.
- If it is slightly worn, recoat the tip with fresh solder to prevent oxidation.
- Check the condition of the surface and inside hole of the nozzle.
- If either is worn or eroded, or the inside diameter seems unusually wide, replace the nozzle.

⚠ CAUTION
The inside hole and the surface of the nozzle is plated with a special alloy. Should this alloy become eroded by high-temperature solder, the nozzle will not be able to maintain the proper temperature.

2. Disassemble the heating element.

⚠ CAUTION
The heating element is very hot during operation.

3. Clean out the hole in the heating element with the provided cleaning pin.

⚠ CAUTION
Be sure the solder in the hole in the heating element is completely heated, before cleaning the hole.

- If the cleaning pin cannot pass through the hole, replace the heating element.
- Turn the power off after cleaning.

Cleaning with the nozzle cleaning pin

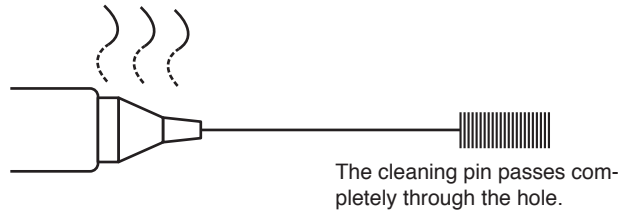

Cleaning with the cleaning drill

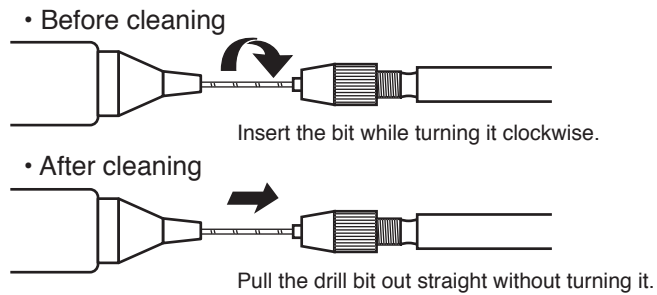

⚠ CAUTION
If the cleaning drill is forced into the nozzle, the drill bit could break or be damaged.

⚠ CAUTION
Please use the proper size cleaning pin or cleaning drill for the nozzle diameter.

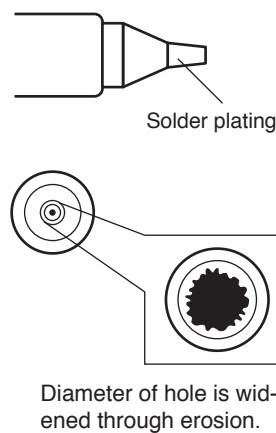

⚠ CAUTION
Unfortunately, it is often difficult to observe this condition. Therefore, if desoldering efficiency goes down and all other parts appear to be OK, the nozzle is probably eroded and should be replaced.

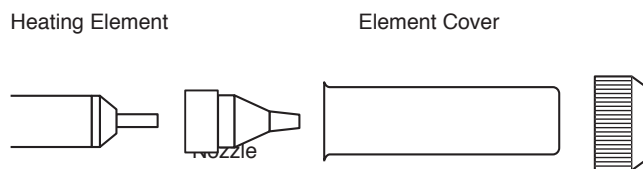

Remove the nut with the attached wrench.

Scrape away all oxidation from the hole in the heating element until the cleaning pin passes cleanly through the hole.

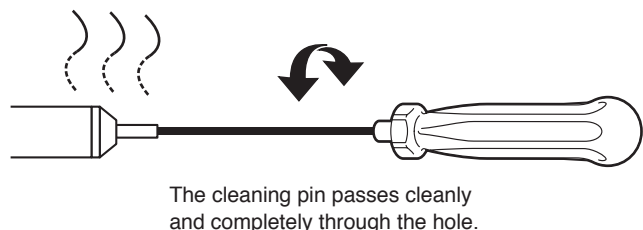

4. Replace the filters.

- Turn the power switch OFF,
- When the filter pipe is cool to the touch, push down the release knob at the back of the gun and remove the filter pipe.

CAUTION
The filter pipe is very hot.

- Examine the front holder.
- Examine the spring filter.
- Examine the ceramic paper filter (L). (No.A1033)

5. Secure the filters.

- Attach the spring filter to the front holder
- Attach the front holder to the filter pipe.

CAUTION
Be sure the front holder is correctly aligned.

CAUTION
Use the ceramic paper filter (L) for the filter pipe (gun). Using of the ceramic paper filter (S) in the filter pipe may cause to break or the power to drop.

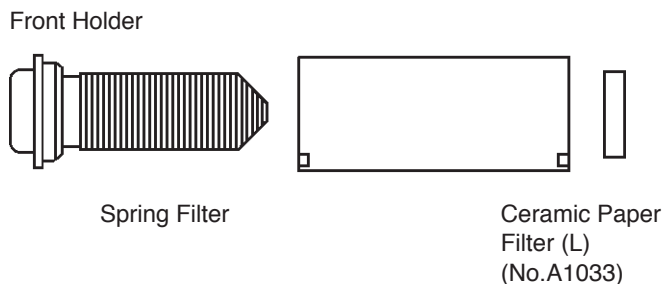

Replace
Stiff and cracked.

Replace
Solder is collected in two-thirds of the spring filter.

Replace
Ceramic paper filter is stiff with flux and solder.

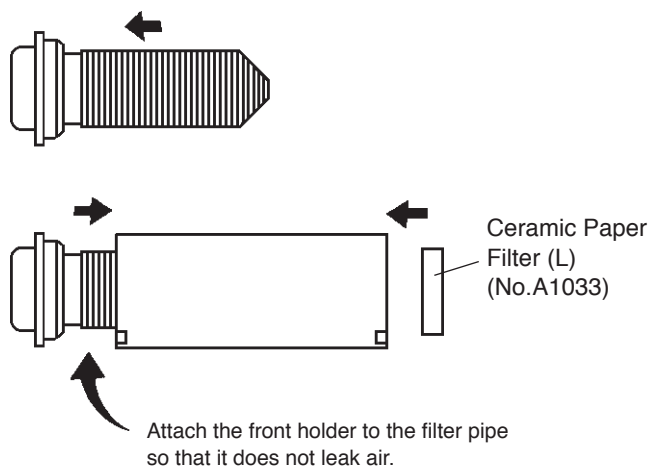

Firmly press the back holder assembly into the filter pipe in order to properly seat the O-ring against the pipe.

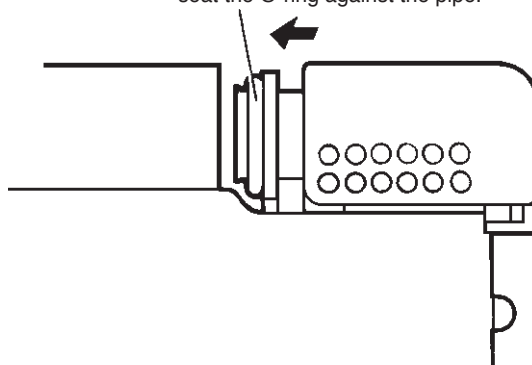

6. Assemble the heating element.

- Attach the nozzle and securely tighten the nut with the attached wrench.

CAUTION
If the nut is loose, air will leak and the temperature will drop.

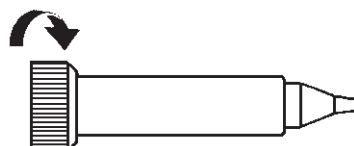

6. Maintenance (Station)

English

Cleaning the inside of the Filter Case

1. Replace the ceramic paper filter (No.A1009).

Remove the ceramic paper filter and inspect it. If it is stiff with flux, replace it.

2. Reassemble the filter case.

⚠ CAUTION

Set the ceramic paper filter (S) for the filter retainer (station).
Using the ceramic paper filter (L) in the filter retainer may cause to break or the power to drop.

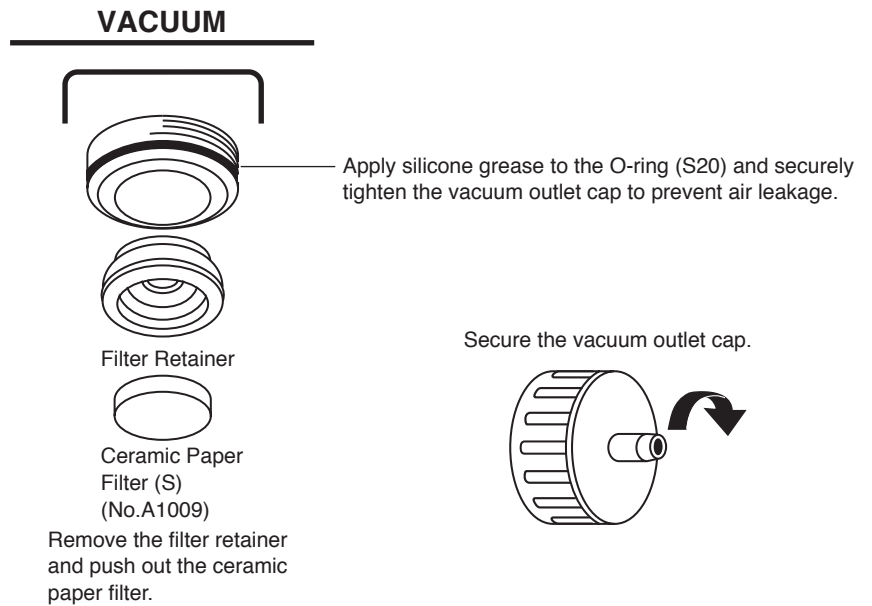

Cleaning the Pump

⚠ WARNING

Unplug the power cord before starting this procedure.

1. Disassemble the pump heads.

- Remove the rear panel.
- Remove the cover.
- Remove the pump head from each side of the pump.

2. Clean the pump head.

- Remove the valve plate and fixing plate.
- Remove any flux adhering to the plates.

⚠ CAUTION

If the fixing plate is difficult to remove, apply hot air to it to warm it up. Never use excessive force to remove the plate as it is easy to bend, and a bent plate will allow air to leak out and reduce solder vacuuming efficiency.

⚠ CAUTION

Clean the plates only with alcohol or thinner.

Replace

If the valve plate is bent or stiff, replace it.

- If the exhaust filter is dirty, replace it.

3. Assemble the pump heads. Reassemble the valve plate and fixing plate.

⚠ CAUTION

When assembling the pump, be sure to check for air leaks.

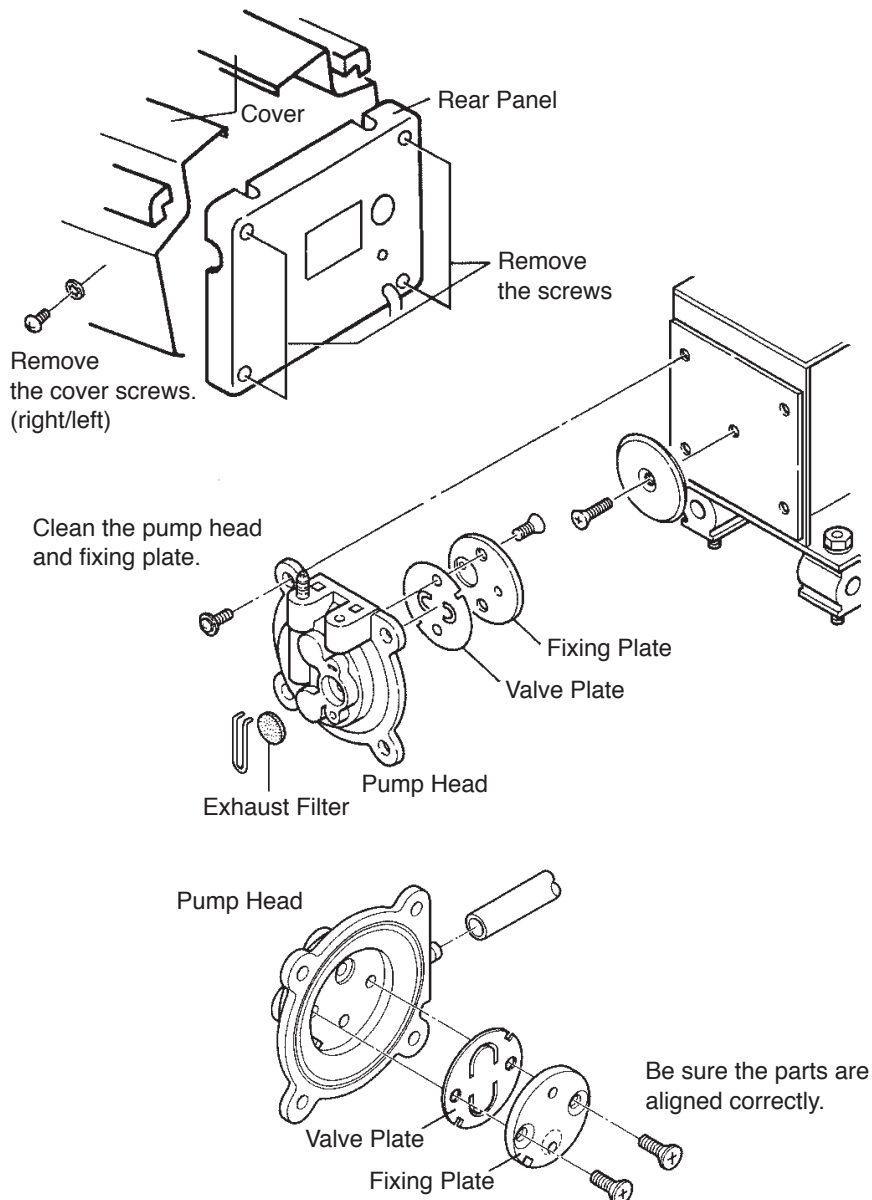

7. Replacement Parts

Replacing the Heating Element

⚠ WARNING
Unplug the power cord before starting this procedure.

The resistance value of a working heating element is 2-4Ω at 23°C (73° F). If the value you get is outside this range, replace the heating element.

1. **Disassemble the heating parts.**
2. **Separate the housing.**
3. **Detach the terminal and remove the heating element.**
4. **Insert a new heating element and reassemble.**
(Heating element 24V-50W)

⚠ CAUTION
Before reassembling enclosure, make sure connectors are completely covered by the glass tube.

5. **Recalibrate the temperature.**
The resistance of new heating element varies, resulting in variations in operating temperatures. It is necessary to recalibrate the temperature every time the heating element is replaced.

- Set the temperature control knob to 1 and allow the gun to warm up for 3 minutes.
- Using a tip thermometer, adjust the temperature calibrator (marked "CAL") until the nozzle temperature reads at 380°C (716°F).

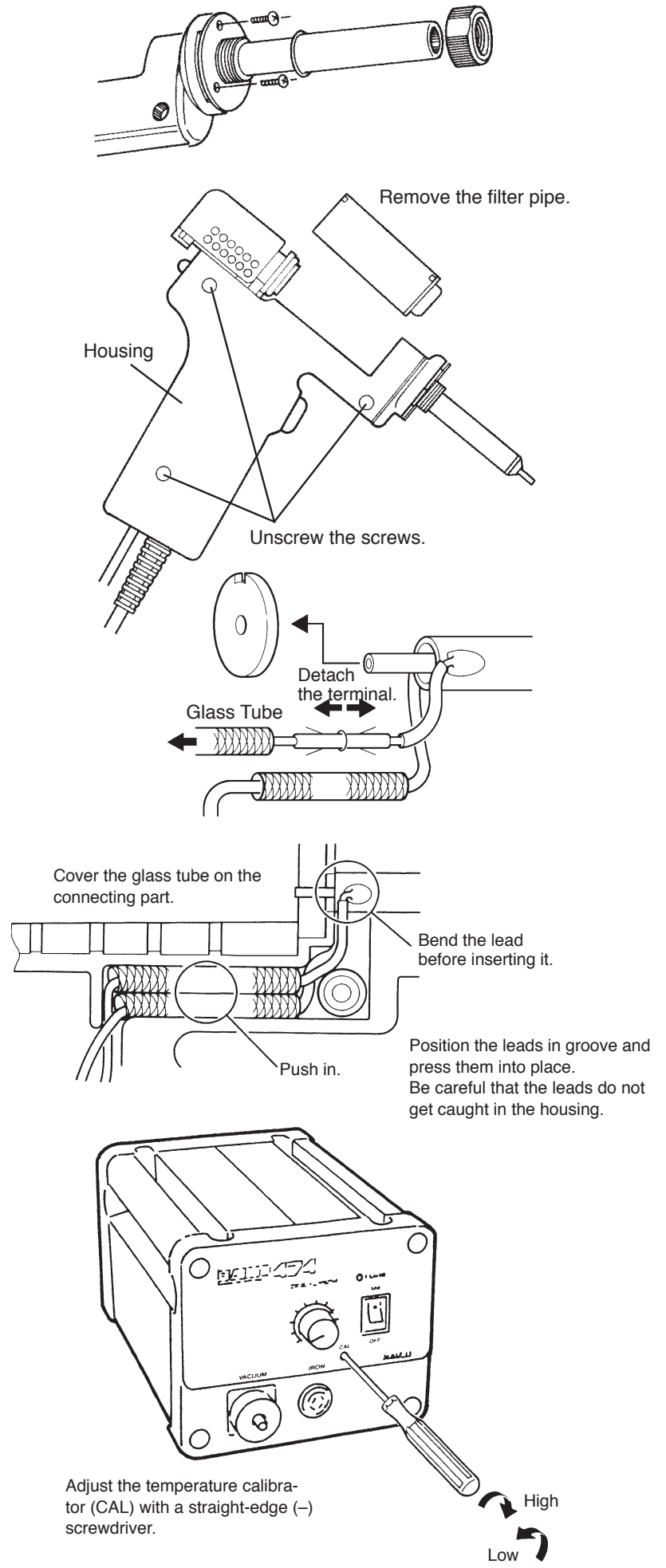

8. Parts List (Station)

Note: Spare or repair parts do not include mounting screws, if they are not listed on the description.

English

Item No.	Part No.	Part Name	Specifications
1	B1029	Vacuum outlet cap	
2	A1009	Ceramic paper filter (S)	10 pcs.
3	B1063	Filter retainer	
4	B1031	Vacuum outlet retainer	W/O-ring (S20)
5	B1034	O-ring (S20)	
6	B1038	Cover for securing screw	Set of 4
7	B1036	Receptacle	
8	B1028	Knob	
9	B2061	Front panel	
10	B1093	Cover	One side
11	B1061	Handle	One side
12	B1044	Temp. control set screw clamp	
13	B2057	P.W.B.	W/potentiometer

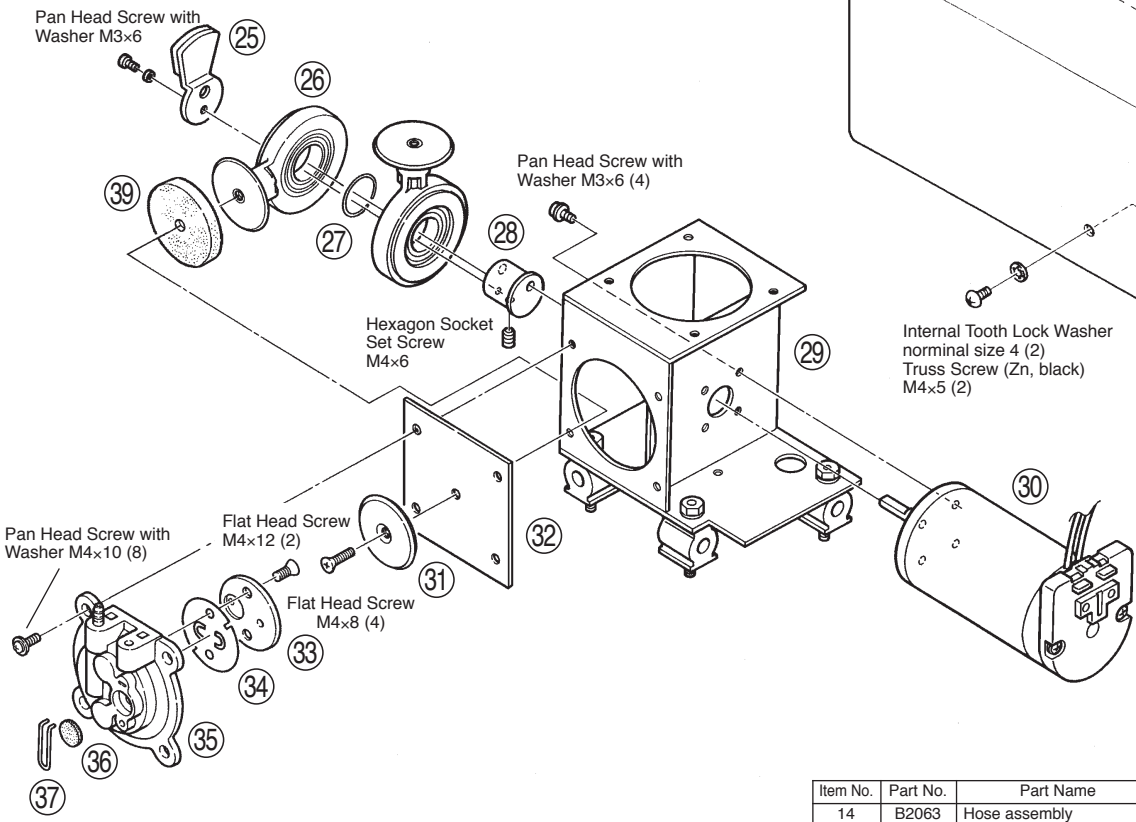
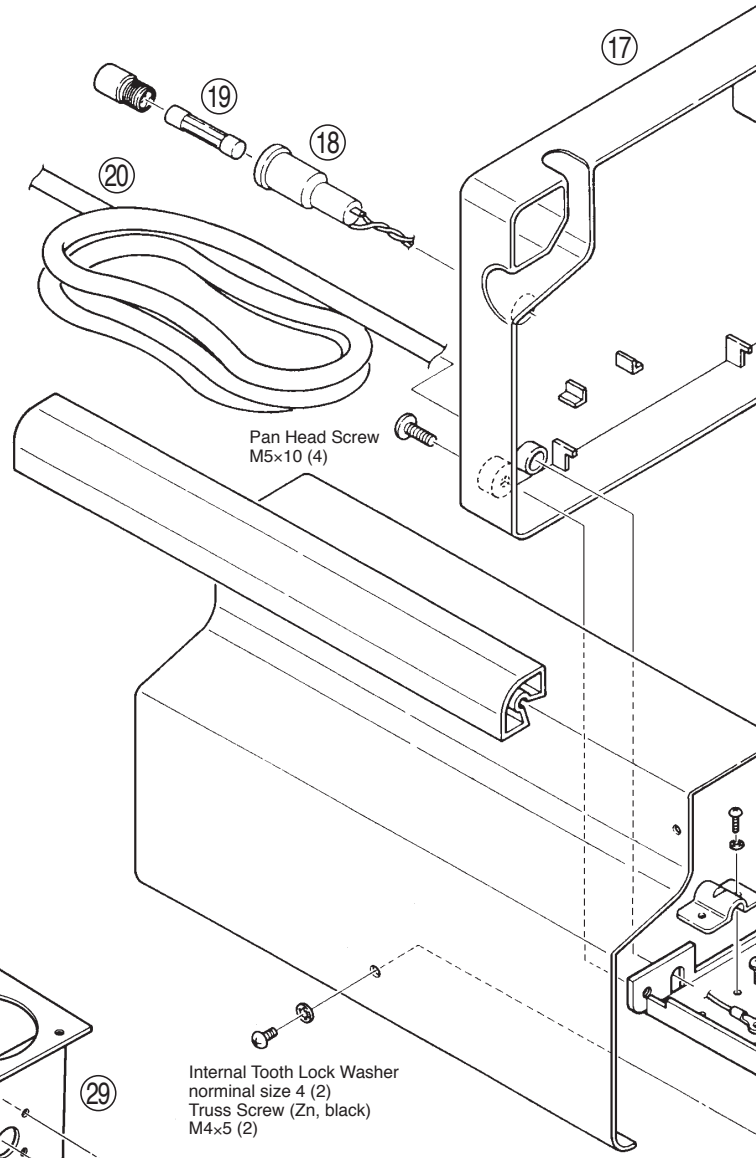

Item No.	Part No.	Part Name	Specifications
14	B2063	Hose assembly	
15	B2065	Transformer	100-24V
	B2077	Transformer	110-24V
	B2078	Transformer	120-24V
	B2080	Transformer	220-24, 230-24, 240-24V
16	B2444	Pump assembly	
17	B2067	Rear panel	W/rating label
	B1041	Fuse holder	w/o fuse
18	B1134	Fuse holder	w/o fuse Australian 240V
	B1042	Fuse	125V-2A/100, 110V
19	B1138	Fuse	250V-1A/220, 230V
	B1139	Fuse	250V-1A(AU)/Australian 240V
	B1275	Fuse	250V-2A(U)/120V

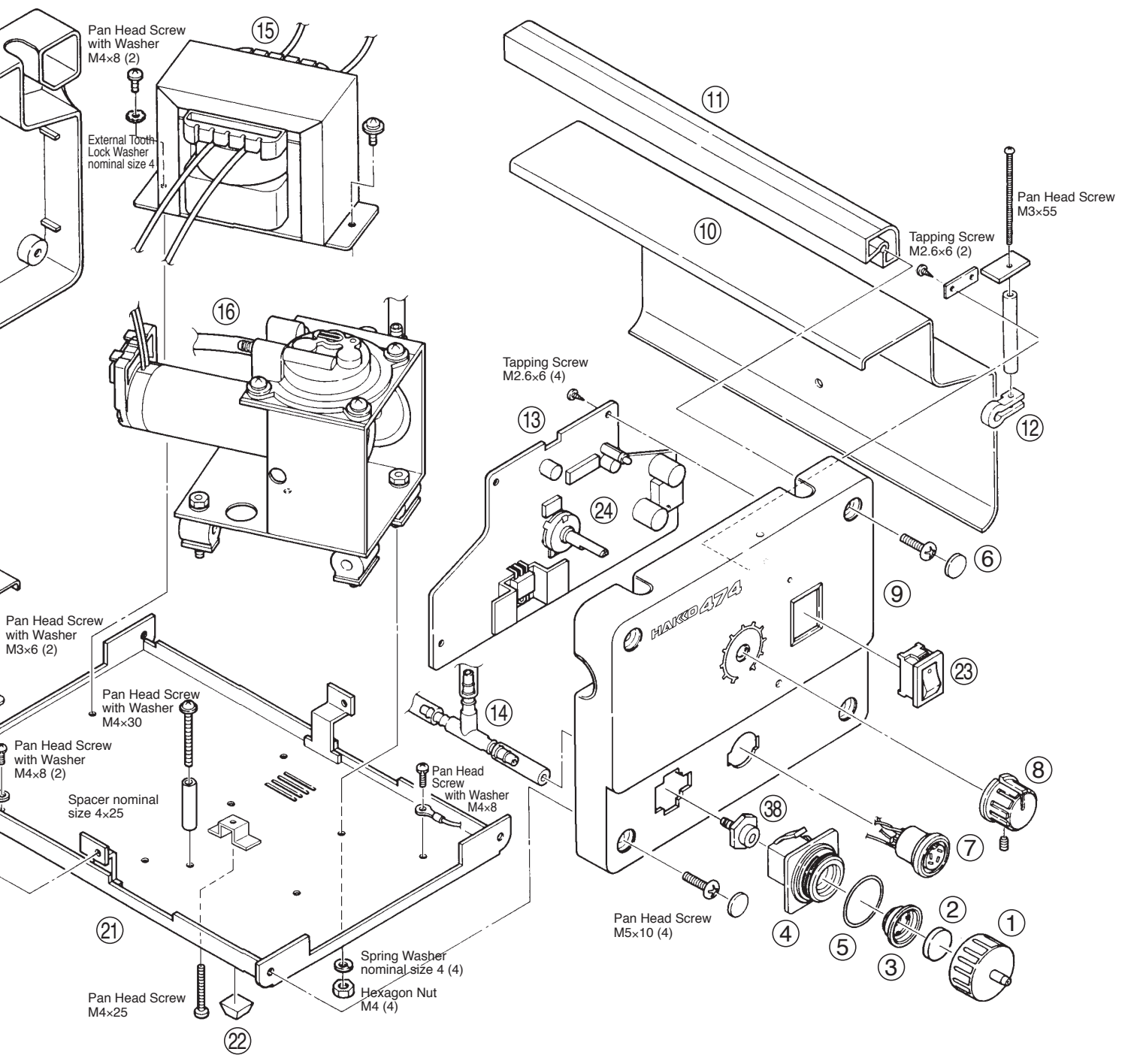

Item No.	Part No.	Part Name	Specifications
20	B2068	Power cord, 3 wired cord & American plug	U.S.A.
	B2079	Power cord, 3 wired cord but no plug	
	B2081	Power cord, 3 wired cord & Australian plug	
	B2082	Power cord, 3 wired cord & BS plug	
	B2083	Power cord, 3 wired cord & European plug	
	B3505	Power cord, 3 wired cord & American plug	
21	B2066	Chassis	
22	B1037	Rubber foot	Set of 4
23	B1084	Switch	
24	B1078	Potentiometer	
25	B1053	Balance weight	
26	B1312	Crank	W/bearing

Item No.	Part No.	Part Name	Specifications
27	B1057	Ring for bearing	
28	B2060	Crank shaft	W/a screw
29	B2059	Pump frame	
30	B2058	Motor	
31	B2085	Diaphragm setting plate	
32	A1013	Diaphragm	Set of 2 W/screws
33	B1056	Fixing plate	
34	A1014	Valve plate	Set of 2
35	B1050	Pump head	W/screws
36	B1059	Exhaust filter	Set of 2
37	B1313	Filter retaining pin	
38	B1064	Filter case joint	
39	B2506	Damper	Set of 2

8. Parts List (Desoldering Gun)

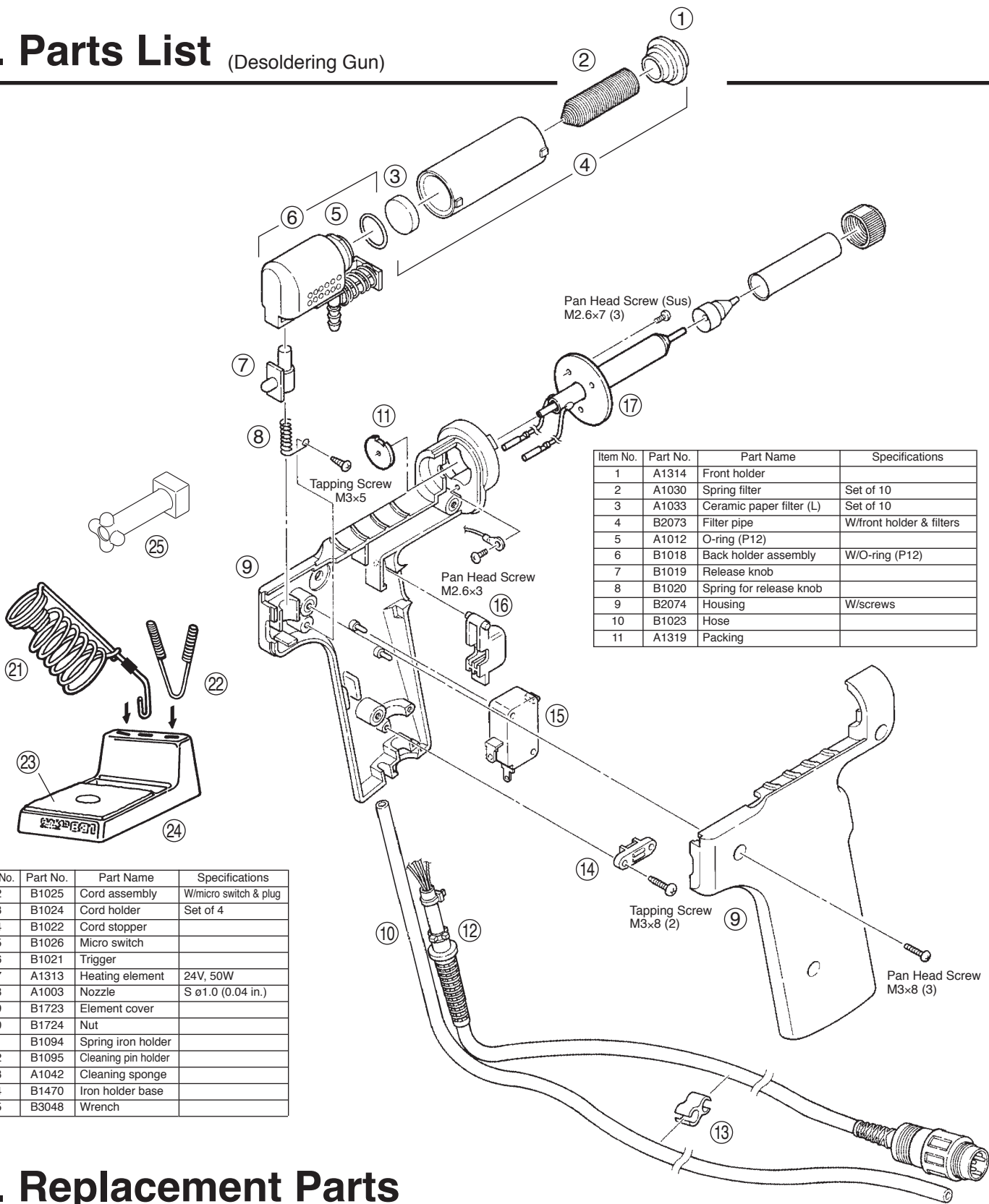

Item No.	Part No.	Part Name	Specifications
1	A1314	Front holder	
2	A1030	Spring filter	Set of 10
3	A1033	Ceramic paper filter (L)	Set of 10
4	B2073	Filter pipe	W/front holder & filters
5	A1012	O-ring (P12)	
6	B1018	Back holder assembly	W/O-ring (P12)
7	B1019	Release knob	
8	B1020	Spring for release knob	
9	B2074	Housing	W/screws
10	B1023	Hose	
11	A1319	Packing	

Item No.	Part No.	Part Name	Specifications
12	B1025	Cord assembly	W/micro switch & plug
13	B1024	Cord holder	Set of 4
14	B1022	Cord stopper	
15	B1026	Micro switch	
16	B1021	Trigger	
17	A1313	Heating element	24V, 50W
18	A1003	Nozzle	S ϕ 1.0 (0.04 in.)
19	B1723	Element cover	
20	B1724	Nut	
21	B1094	Spring iron holder	
22	B1095	Cleaning pin holder	
23	A1042	Cleaning sponge	
24	B1470	Iron holder base	
25	B3048	Wrench	

9. Replacement Parts

Part No.	Part Name	Specifications
A1002	Nozzle S	ϕ 0.8mm (0.03 in.)
A1003	Nozzle S	ϕ 1.0mm (0.04 in.)
A1004	Nozzle	ϕ 0.8mm (0.03 in.)
A1005	Nozzle	ϕ 1.0mm (0.04 in.)
A1006	Nozzle	ϕ 1.3mm (0.05 in.)
A1007	Nozzle	ϕ 1.6mm (0.06 in.)

Part No.	Part Name	Specifications
B1215	Cleaning pin	For heating element
B1086	Cleaning pin	For ϕ 0.8mm (0.03 in.) nozzle
B1087	Cleaning pin	For ϕ 1.0mm (0.04 in.) nozzle
B1088	Cleaning pin	For ϕ 1.3mm (0.05 in.) nozzle
B1089	Cleaning pin	For ϕ 1.6mm (0.06 in.) nozzle
B1302	Cleaning drill	For ϕ 0.8mm (0.03 in.) nozzle
B1303	Cleaning drill	For ϕ 1.0mm (0.04 in.) nozzle
B1304	Cleaning drill	For ϕ 1.3mm (0.05 in.) nozzle
B1305	Cleaning drill	For ϕ 1.6mm (0.06 in.) nozzle
A1028	Silicone grease	

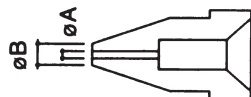
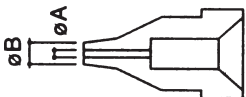

Part No.	ϕ A	ϕ B
A1002	0.8mm (0.03 in.)	1.8mm (0.07 in.)
A1003	1.0mm (0.04 in.)	2.0mm (0.08 in.)

Part No.	ϕ A	ϕ B
A1004	0.8mm (0.03 in.)	2.3mm (0.09 in.)
A1005	1.0mm (0.04 in.)	2.5mm (0.1 in.)
A1006	1.3mm (0.05 in.)	3.0mm (0.12 in.)
A1007	1.6mm (0.06 in.)	3.0mm (0.12 in.)

10. Wiring

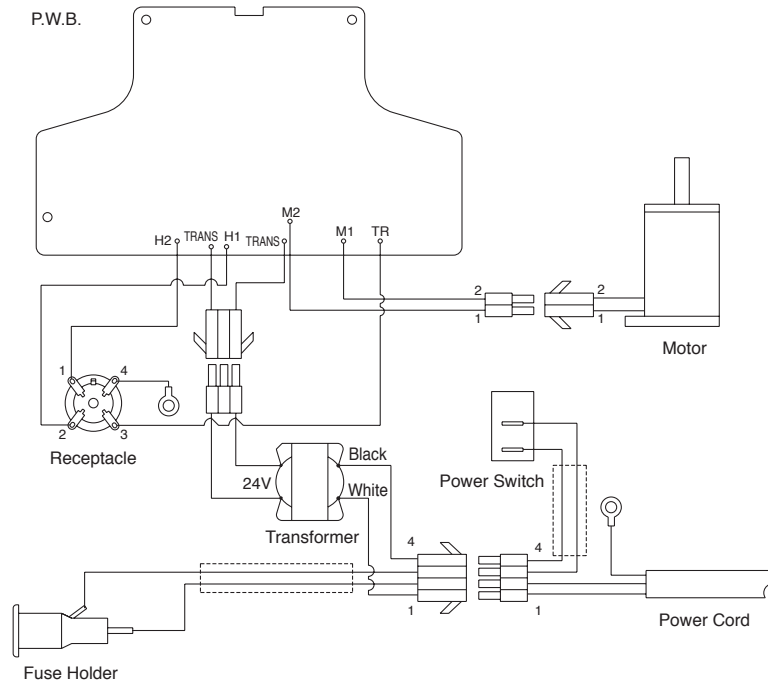

10. 電路圖

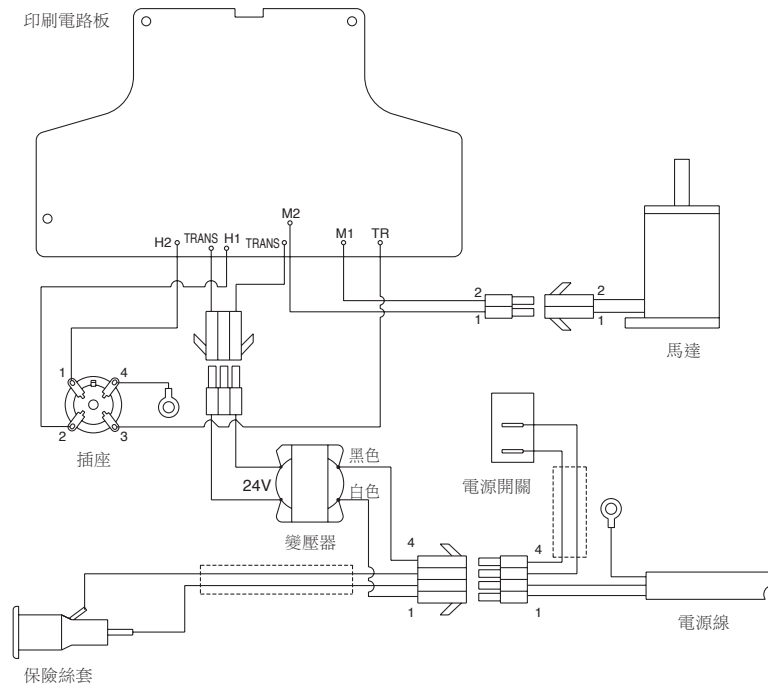

1. 包裝清單

請檢查 HAKKO 474 包裝內容，確保下列部件全在其內。

控制臺.....1	彈簧過濾器.....3
吸錫槍.....1	清潔針 (供 Φ 1.0mm 吸嘴使用).....1
吸錫槍架基座.....1	清潔針 (供發熱元件使用).....1
彈簧式吸錫槍支架.....1	清潔針插架.....1
清潔海綿.....1	清潔鑽 (供 Φ 1.0mm 吸嘴使用).....1
過濾管.....1	硅脂潤滑劑.....1
陶瓷過濾紙 (小).....2	扳手.....1
陶瓷過濾紙 (大).....4	使用說明書.....1

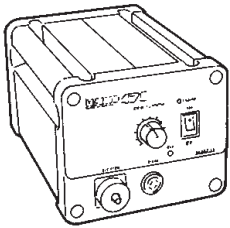

控制臺

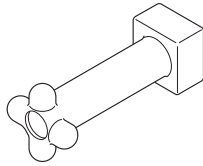

扳手



吸錫槍架基座

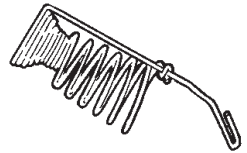

彈簧式吸錫槍支架

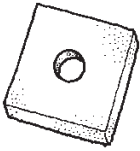

清潔海綿

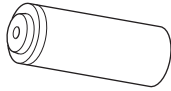

過濾管

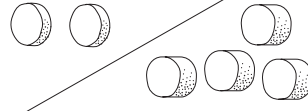

陶瓷過濾紙 (小)

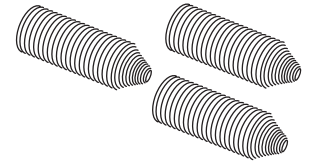

彈簧過濾管

陶瓷過濾紙 (大)

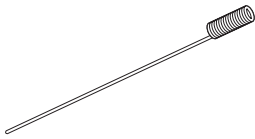

清潔針 (供 Φ 1.0mm 吸嘴使用)

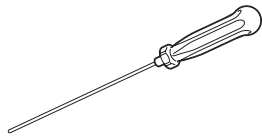

清潔針 (供發熱元件使用)

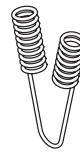

清潔針插架

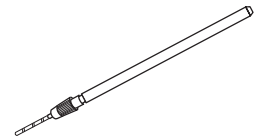

清潔鑽 (供 Φ 1.0mm 吸嘴使用)

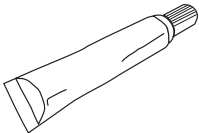

硅脂潤滑劑

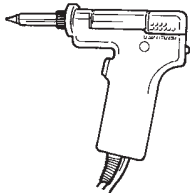

吸錫槍

中文

2. 規格

名稱	HAKKO 474
功率消耗	100W

型號	474
輸出電壓	AC 24V
真空發動	雙柱式真空泵
真空壓力 (最高)	80KPa(600mmHg)
吸入流量	15l/min.
焊鐵頭至接地電阻	2 Ω 以下
焊鐵頭至接地電勢	2mV 以下
外部尺寸	165(W) \times 135(H) \times 260(D)mm
重量	約 3.8Kg

●吸錫槍

型號	809
編號	C1183
發熱元件	AC 24V/50W 陶瓷
溫度	380 — 480 $^{\circ}$ C
絕緣電阻	在 420 $^{\circ}$ C時大於 300M Ω
吸嘴內直徑	Φ 1.0mm(吸嘴 S 型標準)
部件尺寸	135(W) \times 174(H)mm
重量 (不包括電線, 軟管)	約 200g

* 本產品有防靜電處理。
* 規格及外觀，可能改良變更，恕不先行通知。



測量條件

- 絕緣電阻
使用一個 DC500V 的絕緣電阻測量計，在吸嘴和發熱元件引線之間測量絕緣電阻。
注意：不可在吸嘴和電源插座之間測量絕緣電阻，因為第二側是與第一側和變壓器絕緣。
- 漏電壓
使用交流電毫伏測量計，在吸嘴和接地插座之間，於 480 $^{\circ}$ C 的情況下，進行測量漏電壓。
注意：控制臺必須接地，才可進行測量漏電壓。
- 規格及外觀可能改良變更，恕不先行通知。

3. 安全及使用上的注意事項

本使用說明書如下所述將注意事項區分為「警告」「注意」來表示。請理解其含意後再閱讀本文。

警告

-  **警告：** 濫用可能導致使用者死亡或重傷。
-  **注意：** 濫用可能導致使用者受傷或對涉及物體造成實質破壞。

注意

使用之前必須除去控制臺底下的泵拴緊螺絲 (M4×25 紅色記號), 否則可能導致嚴重後果。

當電源接通時, 吸嘴溫度介於 380 至 480°C。
鑒于濫用可能導致灼傷或火患, 請嚴格遵守以下事項。

- 切勿觸及吸嘴周圍的金屬部分, 塑料部分和彈簧式吸錫槍支架。
- 切勿在易燃物體附近使用吸錫槍。
- 通知工場其他人士, 吸錫槍極為炙熱, 可能引發危險事故。
- 休息時或完工後, 應關掉電源, 並待吸錫槍冷卻至室溫。
- 更換部件或裝配吸錫槍時, 應關掉電源, 並待吸錫槍冷卻至室溫。

為避免損壞吸錫槍及保持作業環境之安全, 應遵守下列事項。

- 切勿使用吸錫槍進行吸錫以外的工作。
- 切勿以吸錫槍敲擊工作臺以清除焊錫殘餘, 此舉可能嚴重震損吸錫槍。
- 切勿擅自改動吸錫槍。
- 更換部件時, 應採用 HAKKO 原件。
- 切勿弄濕吸錫槍, 手濕時也不可使用吸錫槍。
- 陶瓷過濾紙 (小) 只可裝在控制臺過濾器內, 而陶瓷過濾紙 (大) 只可裝在吸錫槍過濾管內。
- 應定期保養吸錫槍和控制臺。
- 使用吸錫槍時, 不可做出任何可能傷害身體或損壞物件的妄動。



中國RoHS: 產品中有毒有害物質或元素的名稱及含量

部件名稱	有毒有害物質或元素					
	鉛(Pb)	汞(Hg)	鎘(Cd)	六價鉻 (Cr(VI))	多溴聯苯 (PBB)	多溴二苯醚 (PBDE)
泵組件	×	○	○	○	○	○
過濾管接合套	×	○	○	○	○	○
吸錫槍部	×	○	○	○	○	○
電路板	×	○	○	○	○	○
保險絲套	×	○	○	○	○	○
清潔鑽	×	○	○	○	○	○
插頭	×	○	○	○	○	○

○：表示該有毒有害物質在該部件所有均質材料中的含量均在SJ/T 11363-2006 標準規定的限量要求以下。
 ×：表示該有毒有害物質至少在該部件的某一均質材料中的含量超出SJ/T 11363-2006 標準規定的限量要求。

 **注意**
 本產品施有防靜電措施, 對塑膠導電性, 並對焊鐵部與機身部作接地, 請特別留意下列注意事項:
 1. 手柄等之塑膠, 並非絕緣物, 而是有導電性塑膠, 修理時請十分注意之。進行部件更換或修理時, 有電部分不可露出, 及切勿損傷絕緣材料。
 2. 請務必接地使用之。

4. 部件名稱

請查閱第 29,30,31 頁之部件編號。

●吸錫槍

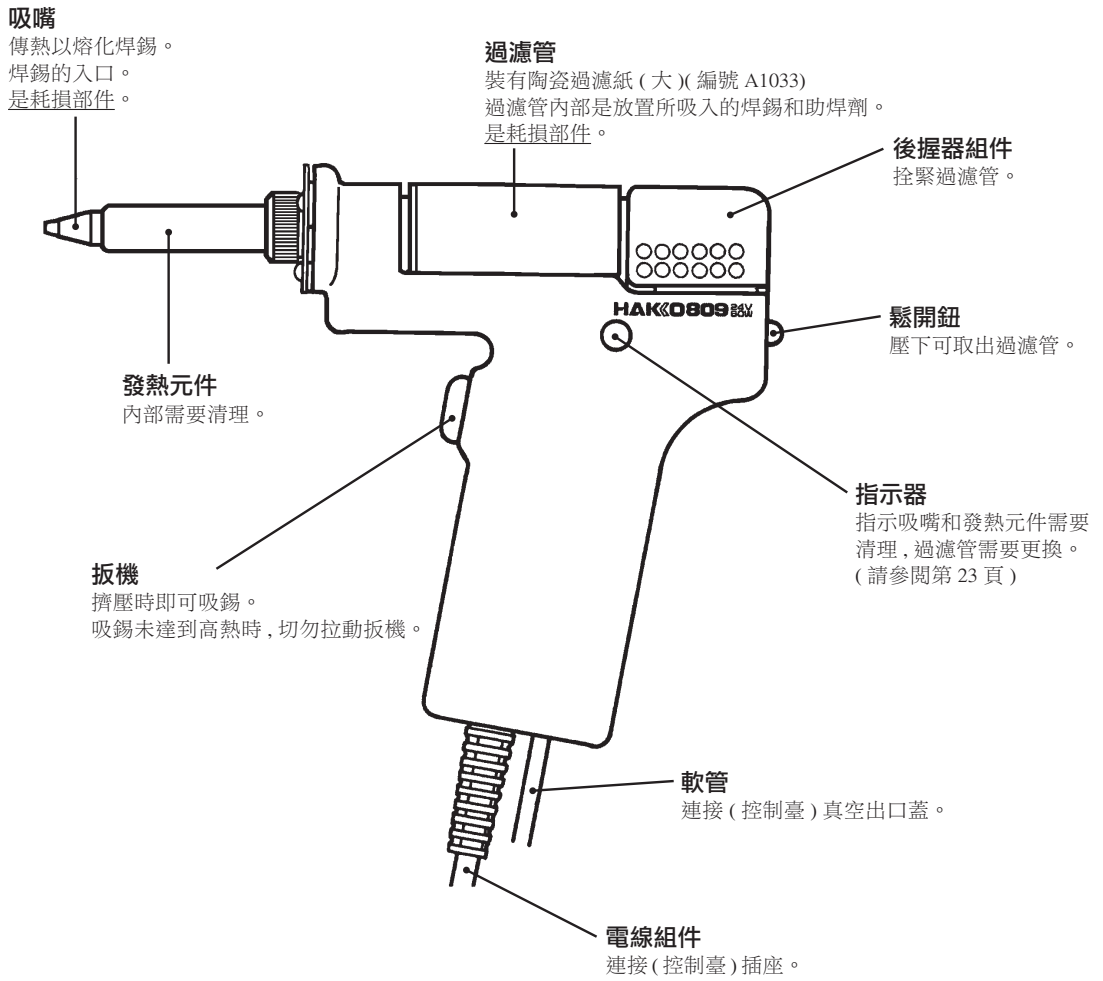

●控制臺

溫度控制鈕
提供吸嘴溫度控制。
(請參閱第 21 頁)

溫控定位螺絲夾
可防止溫控鈕變動而需重新調節。
(請參閱第 21 頁)

電源指示燈
電源開關為"開"時,燈亮。

電源開關
電源開關為"開"時,發熱元件開始發熱。

校準計
更換發熱元件後,用以校準溫度。

真空出口蓋
設置陶瓷過濾紙(小)
(編號 A1009)
連接軟管。
真空出口蓋內陶瓷過濾紙是耗損部件。

插座
連接電線組件。

- 保險絲座**
- 100V,110V 單位
含有 125V-2A 保險絲
 - 120V 單位
含有 250V-2A(U) 保險絲
 - 220V,230V 單位
含有 250V-1A 保險絲
 - 澳洲 240V 單位
含有 250V-1A 保險絲

電源線

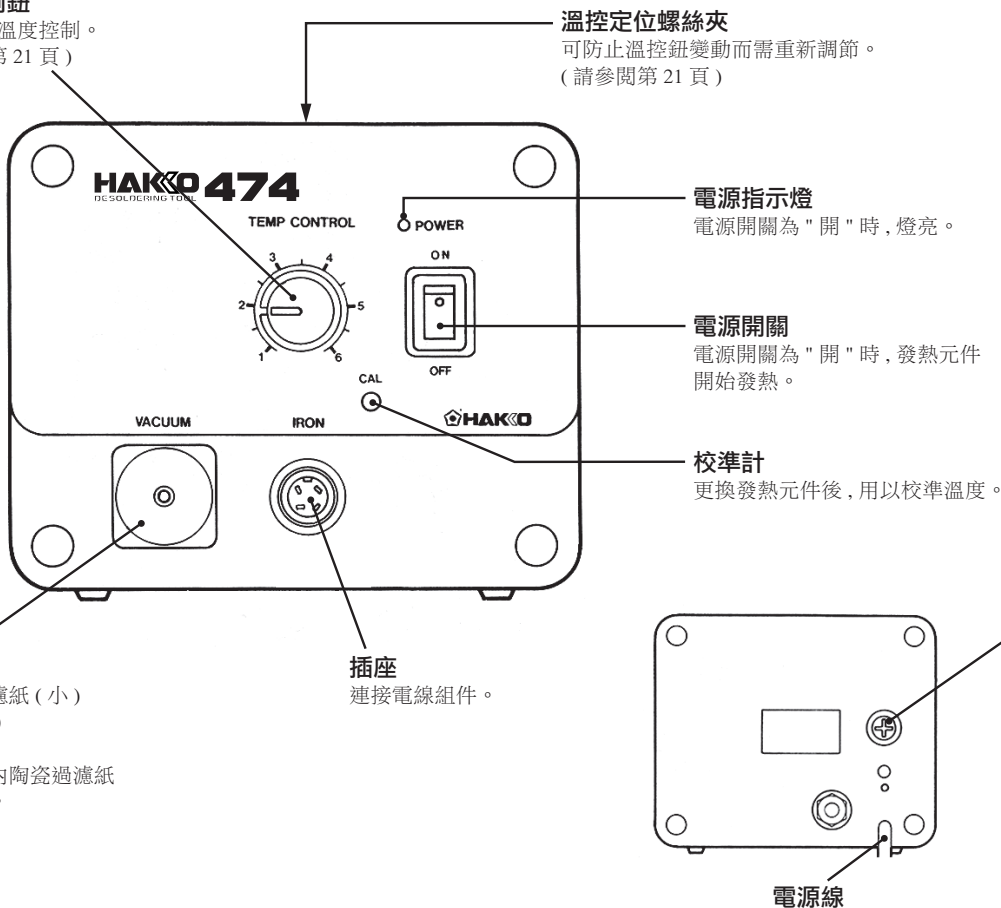

5. 使用

準備 --- 裝配和連接

在平面臺上裝配 HAKKO 474。

1 請鬆開控制臺底下的泵控緊螺絲 (M4 × 25 紅色記號)。

2 裝配吸錫槍支架

- 裝彈簧式支架和清潔針插架插入基座。
- 裝清潔海綿浸在水中，取出擠乾。

⚠注意

海綿是壓縮體，濕水後會膨脹。應移去海綿的圓環部份。

3 插入吸錫槍和清潔針

- 將吸錫槍完全插入彈簧式支架內。

⚠注意

使用吸錫槍時，彈簧式支架變得非常炙熱。使用吸錫槍時及使用後不久，切勿觸摸彈簧式支架。

4 連接

⚠注意

進行連接或裝電線組件拔出插座之前，切記要關掉電源，否則可能損壞印刷電路板。

- 裝電線組件連接插座。
(“IRON” 記號)
- 裝軟管連接真空出口蓋
(“VACUUM” 記號)

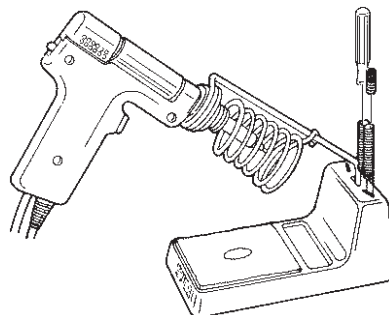
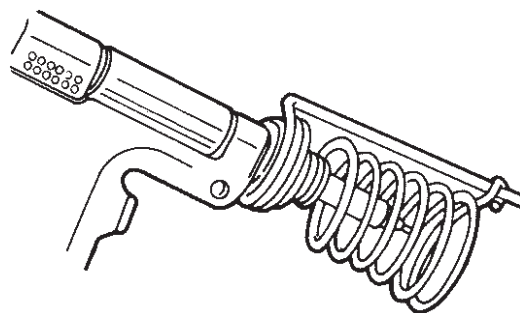
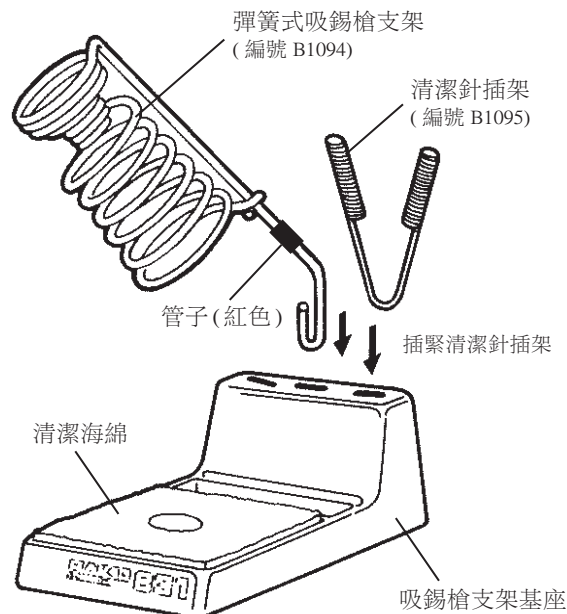

IRON

IRON



裝電線組件插入插座

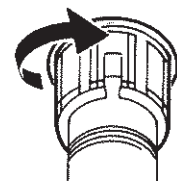

順時針方向旋緊插座

VACUUM

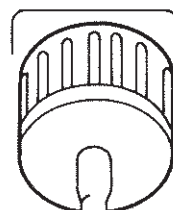
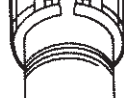

將軟管完全插入
真空出口蓋

5. 使用

5 電源開關

- 電源開關按 " 關 " 時，才可將插座通電源。

⚠注意

整臺吸錫槍都選用導電材料製成，因此各部件都應接地。

- 電源開關按 " 開 " 時，電源指示燈會著亮。
- 電源開關按 " 開 " 時，吸嘴開始發熱。

6 電源開關按 " 開 " 後 3 分鐘，才可進行吸錫工作。

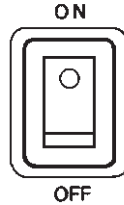

電源指示燈著亮

電源指示燈不亮

1. 電線組件是否連接妥當？
2. 保險絲是否熔斷？



吸嘴發熱

吸嘴不熱

1. 電線組件是否連接妥當？
2. 發熱元件是否斷裂？

⚠注意

不使用吸錫槍時，應插入吸錫槍支架內。

吸錫

電源開關按 " 開 " 後 3 分鐘，才可開始吸錫工作。

1 設定溫度

⚠注意

工作時，應儘量調低溫度。

- 為了更精確調節溫度，先用焊鐵溫度計測量吸錫溫度，然後依此調節溫控鈕的溫度。

我們建議使用 HAKKO 191 溫度計，或 HAKKO 192 焊鐵測試器，以測量吸嘴溫度。

- 拴緊 HAKKO 474 控制臺頂端的溫控定位螺絲夾（十字帽螺絲），以鎖定溫控鈕。

溫控鈕的溫度，可調節在 380 至 480°C 之間。請參照下表，調節溫控鈕：

溫控鈕	印刷電路板
1-2	單面印刷電路板
3-4	穿孔印刷電路板
5-6	多層印刷電路板

⚠注意

切勿將清潔針插入溫控定位螺絲夾的孔徑裡，這會損壞吸錫槍。

⚠注意

切勿將清潔針插入溫控定位螺絲夾的孔徑裡，這會損壞吸錫槍。



使用十字帽螺絲起子，拴緊溫控定位螺絲夾。

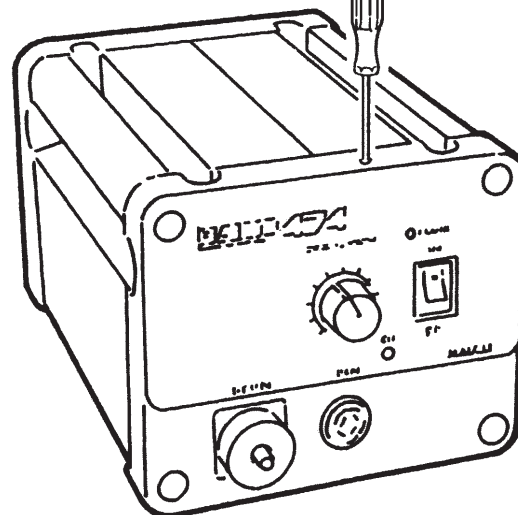

2 清理吸嘴

- 以少量焊錫在吸嘴的焊錫鍍層部份塗上保持吸嘴有光澤。

如果吸嘴覆蓋有氧化劑，導電能力便減弱。在吸嘴頭鍍上少量新焊錫，可發揮最大導電功能。

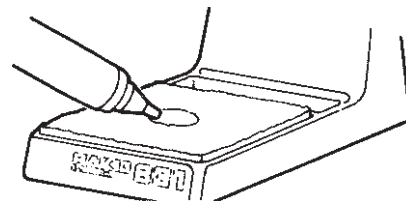

利用海綿中央位置的孔徑，以清除吸嘴上的氧化劑或舊焊錫。

3 熔化焊錫

- 將吸嘴觸及所要熔化的焊錫部位。

⚠注意

切勿讓吸嘴觸及印刷電路板。

- 確定焊錫已被熔化

⚠注意

要確定焊錫是否已完全被熔化，可觀察孔徑內和印刷電路板的背面。如果有困難，則可用吸嘴稍搖動引線腳，如果可以移動，則表示焊錫已被熔化。

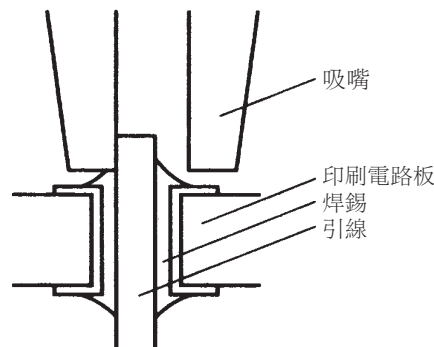

4 吸除焊錫

- 確定焊錫已完全被熔化後，擠壓吸錫槍扳機，即可吸入焊錫。

⚠注意

切勿遺留任何焊錫殘餘在印刷電路板孔徑內。

- 吸淨後，可以冷切焊接點，以防止焊錫再次被熔化。

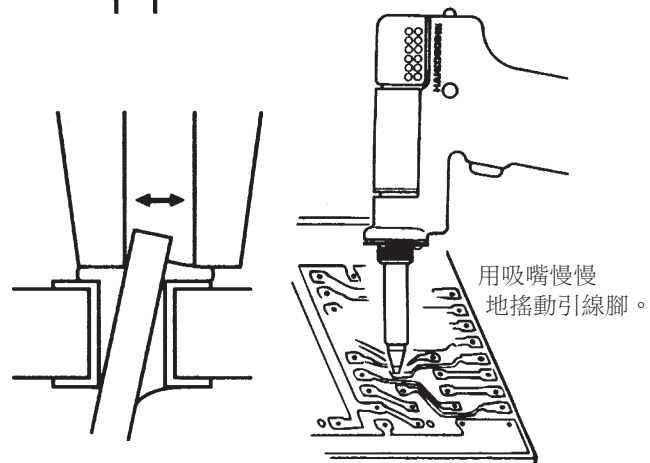

5 吸錫時發生故障

- 如果遺留下焊錫殘餘，電路塊須重新焊接，再重復上述吸錫過程。

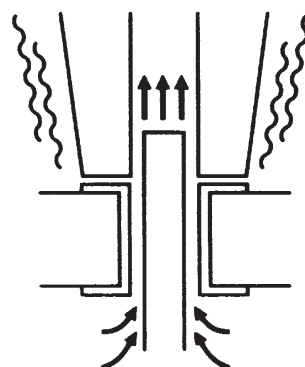

慢慢來往移動吸嘴，以吸入焊錫。

5. 使用

發熱的焊錫和助焊劑會產生氧化物，附著在吸嘴上和發熱元件內部。這些氧化物不但降低熱傳導，也會阻塞吸嘴和發熱元件，以致吸力減弱。如果工作進行時，發現吸力顯著減弱，即需更換過濾管，並以所供應的清潔針，清理吸嘴和發熱元件。

使用時，進行清理工作

1 觀察指示燈

觀察指示燈，吸嘴孔必須張開。
拉動扳機，再觀察指示燈。如果是紅色，表示要清理吸嘴和發熱元件。倒空過濾管，然後再更換過濾管。如果是藍色，則不須清理，可繼續使用。

⚠注意



如果吸嘴孔堵塞，或者印刷電路板孔徑內的焊錫未被熔化，指示燈操作便不準確。

⚠注意

HAKKO 475 的查讀法不同。請查閱 HAKKO 475 使用說明書，以了解如何查讀 HAKKO 475 指示燈。

2 更換過濾管

更換過濾管過程請參照 1 ~ 3。
工作進行時，過濾管非常炙熱，須等待過濾管冷切時，才可更換過濾管。我們建議，先準備好第二個內置有新過濾器的過濾管，以備不時之需。

正常	不正常	解決方法
		如果指示燈一半以上是紅色，需更換過濾管，並清理吸嘴和發熱元件的內部（請參閱第 25 頁吸錫槍的保養）
可看見藍色或些微紅色	指示燈一半以上是紅色	

⚠注意

如果吸力顯著減弱，應以清潔針清理吸嘴和發熱元件。

- 3 以所提供的備用過濾管來更換整條過濾管。

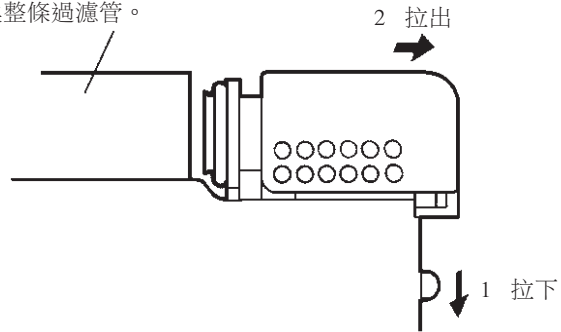

除錫時發生故障

- A. 焊接點上的焊錫未全然溶化。
- B. 吸力減弱。

A. 焊接點上的焊錫未全然被溶化。

· 溫度不夠高

下列部件需有高溫才能吸錫。

- 多層印刷電路板，電供，穿洞電路板高能半導體的平面板，具有熱輻射傳熱片的三端雙向開關部件，印刷電路板接地電線調頻器，以及大型半導體終端等。

利用預熱爐或發熱槍，先將印刷電路板昇溫到不至于損壞板面或其元件的熱度，即 70 ~ 80°C 之間，然後吸錫。切勿重新校準，以提高發熱槍溫度，如此會損壞印刷電路板及其元件。

· 吸嘴耗損

- 當吸嘴開始耗損時，發熱效能減弱。請檢查吸嘴。如果是鍍錫層磨損（參照第 25 頁），或吸嘴受腐蝕（參照第 25 頁），應更換吸嘴。

使用後的保養

使用 HAKKO 474 吸錫槍後，應依照右列程序進行保養，以確保經久耐用。

排除故障指南

B. 吸力減弱

- 更換過濾器，清理吸嘴及發熱元件內部。(參照第 25_26 頁，吸錫槍和機身維修)

● 真空系統漏氣

指示燈不能表示漏氣情況。

檢查下列部件的密封空氣，如有損壞便應該更換：

- | | |
|-----------------|-----------------|
| a. 吸嘴接觸點和發熱元件 | d. 軟管 |
| b. 過濾管前端蓋及其周圍部件 | e. 真空出口蓋 |
| c. 後握器的圓環 | f. 連接電線裝配及其周圍部件 |

- 清除吸嘴內和發熱元件的焊錫。
- 用清潔海綿清理吸嘴後，在吸嘴頭鍍上一層新焊錫，以保護鍍吸層。

⚠ 警告 如果電源線損壞，應請製造商，或其代理商，或合格人士更換，以免發生傷人或損壞機身事故。

● 電源指示燈不亮？

- 電源線是否插妥？**
將插座插緊電源。
- 保險絲是否熔斷？**
檢查出保險絲熔斷的原因，排除故障，並更換新保險絲。
例如 吸錫槍內部是否短絡？

● 泵不能操作

- 電線組件是否妥當接通？**
重新接通電線組件。(參閱第 20 頁)
- 吸嘴或發熱元件內部的孔徑是否阻塞？**
必須清理。(參閱第 25 頁)

● 不能吸錫

- 彈簧過濾管是否充塞焊錫？**
更換新彈簧過濾管。(參閱第 26 頁)
- 陶瓷過濾紙是否硬化？**
更換新陶瓷過濾紙。
- 真空艙是否裂漏？**
檢查連接部份，更換任何損壞部件。(參閱第 24 頁)

● 吸嘴不熱

- 吸錫槍的電線組件是否連接妥當？**
重新連接。(參閱第 20 頁)
- 發熱元件是否損壞？**
更換新發熱元件。(參閱第 28 頁)

註 交付修理時，請將吸錫槍和控制臺一起交給銷售商檢修。

6. 保養 (吸錫槍)

妥善保養 HAKKO 474 吸錫槍，保持高性能，可使用多年。
吸錫效率視溫度，焊錫和助焊劑的質量和數量而定。請根據吸錫槍的使用條件，依照下列維修程序進行保養。

警告 吸錫槍可達到極高溫度，應小心使用。除了清潔吸嘴及發熱元件以外，必須維持電源線是關的。當進行任何保養之前電源插頭必須是未連接的。

吸錫槍維修

注意
吸錫槍十分炙熱，維修時，應戴上手套，小心工作。

1 檢查和清理吸嘴

- 將插頭插入電源插座，電源開關"開"，使吸嘴發熱。
- 以吸嘴清潔針清理吸嘴孔徑。

注意
吸嘴內的焊錫若未完全被熔化，清潔針不能貫通吸嘴。

- 如果清潔針不能貫通吸嘴孔，可用清潔鑽清理。
- 檢查吸嘴頭的鍍錫層。
- 如略有耗損，請用新焊錫重新沾上吸嘴頭，避免引起氧化作用。
- 檢查吸嘴孔徑內外。
- 如果吸嘴孔徑內外都已耗損或受腐蝕，或者孔徑似乎反常擴大，應更換吸嘴。

注意
吸嘴孔徑內外均鍍有一層特殊合金層。如果合金層因高溫焊錫而受到腐蝕，吸嘴便不能保持適當溫度。

2 拆開發熱元件

注意
使用時，發熱元件非常炙熱。

3 以所提供的清潔針來清理發熱元件孔徑

注意
發熱元件孔徑內的焊錫必須完全被熔化，才可以清理孔徑。

- 如果清潔針不能貫通孔徑，要更換發熱元件。
- 清理後必須關掉電源。

以清潔針清理吸嘴



以清潔鑽清理吸嘴

· 清理前

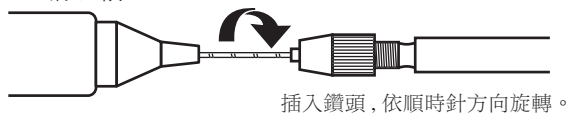

· 清理後

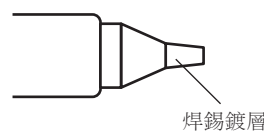
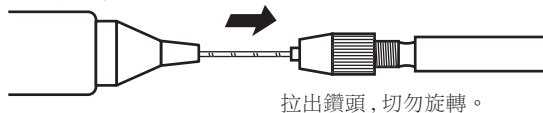

注意
如果使勁強力插入清潔鑽，鑽頭可能斷裂或損壞。

注意
請依照吸嘴直徑，選用尺寸相配的清潔針或清理鑽。

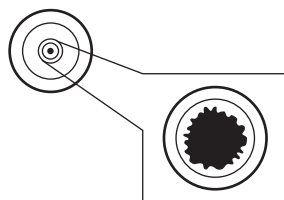

注意
因肉眼難於觀察到吸嘴的腐蝕情況，如果吸錫效率減低，而所有其他部件性能都環完好，那可能是吸嘴受腐蝕，應更換新的吸嘴。

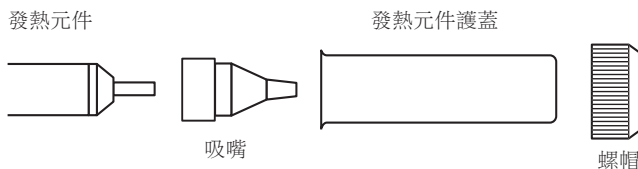

以所提供的扳手來鬆開螺帽。

清除發熱元件孔徑內的氧化物，直到清潔針可完全貫通為止。

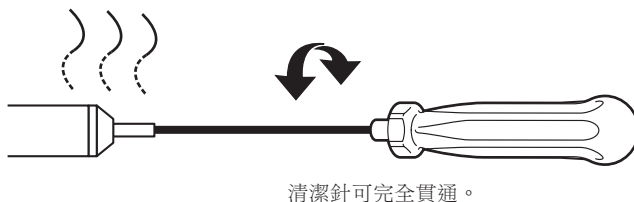

4 更換過濾管

- 電源開關按 " 關 "。
- 當過濾管冷卻而可用手觸摸時，按下吸錫槍背面的鬆開鈕，取出過濾管。

⚠注意

過濾管非常炙熱。

- 檢視前端蓋。
- 檢視彈簧過濾管。
- 檢視陶瓷過濾管 (大)
(編號 A1033)

5 旋緊過濾管

- 將彈簧過濾管安裝在前端蓋。
- 將前端蓋安裝在過濾管上。

⚠注意

前端蓋的安裝位置必須準確。

⚠注意

將陶瓷過濾紙 (大) 裝進 (吸錫槍) 過濾管。
如用陶瓷過濾紙 (小) 裝進過濾管，可能損壞吸錫槍，或降低吸錫效率。

6 裝配發熱元件

- 裝上吸嘴，以所提供的扳手來拴緊螺帽。

⚠注意

如果螺帽未拴緊，空氣漏出，則溫度降低。

前端蓋

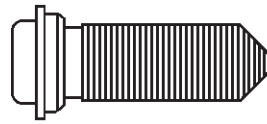

彈簧過濾管

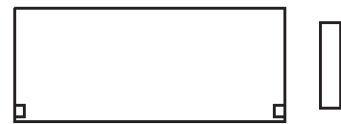

陶瓷過濾紙 (大)
(編號 A1033)

更換

僵硬且裂開。

更換

彈簧過濾管積儲三分之二焊錫時。

更換

陶瓷過濾紙因淤積焊錫和助焊劑而僵硬。

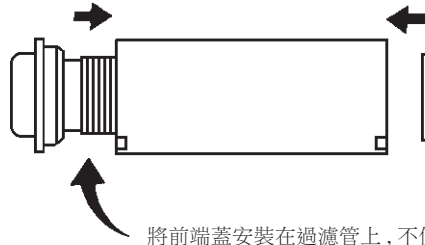
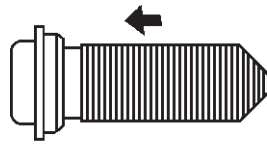

陶瓷過濾紙 (大)
(編號 A1033)

將前端蓋安裝在過濾管上，不使空氣漏出。

將後握器組件壓入過濾管中，使之緊貼在管背的圓環。

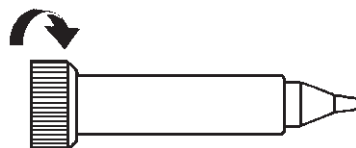
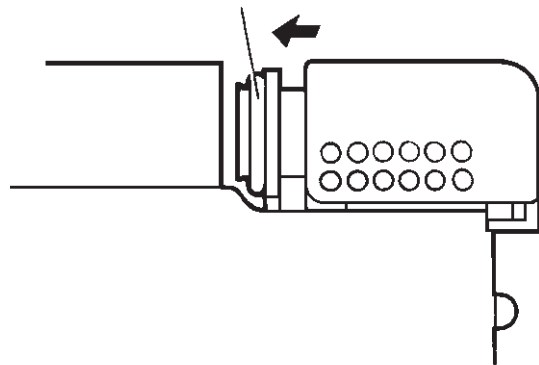

6. 保養 (控制臺)

清理過濾管內部

1 更換陶瓷過濾紙 (編號 A1009)

取出陶瓷過濾紙檢視, 如果塞滿助焊劑而僵硬, 應更換。

2 重裝過濾管內部

⚠注意

以陶瓷過濾紙 (小) 裝入 (控制臺) 濾槽護圈。
若錯以陶瓷過濾紙 (大) 裝入, 可能損壞吸錫槍, 降低效率。

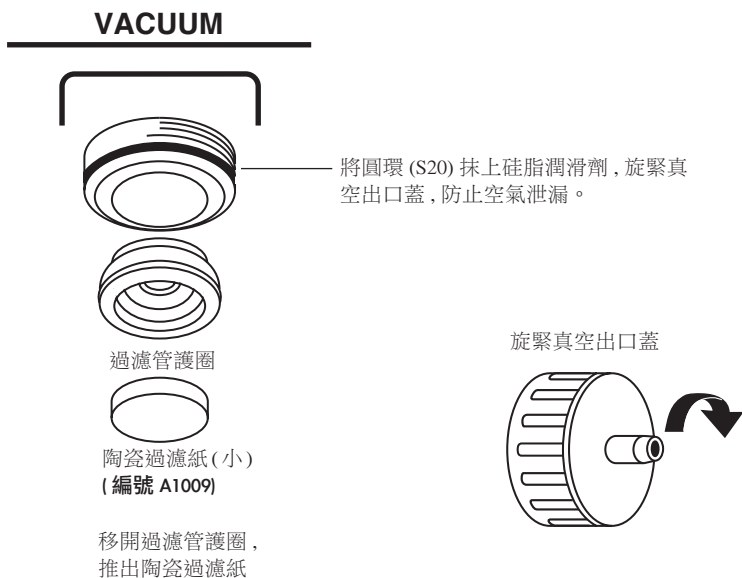

清理泵

⚠警告

將電源線拔出電源插座後, 才可以按照以下程序進行保養。

1 拆開泵頭

- 拆開後蓋。
- 移去護罩。
- 從泵兩邊取出泵頭。

2 清理泵頭

- 移開片閥和固定片。
- 除去黏在片上的助焊劑。

⚠注意

如果固定片難於拆下, 可噴以熱氣使之鬆脫。固定片易彎曲, 切勿使勁強力拆下。彎曲的固定片會漏氣, 減低吸錫真空效率。

⚠注意

可用酒精或稀淡劑來清理片閥和固定片。

更換

如果片閥彎曲或硬化, 應更換之。

- 如果排氣過濾管骯髒, 應更換之。

3 裝置泵頭

按照拆開步驟, 回裝片閥和固定片。

⚠注意

裝置泵時, 應檢查是否漏氣。

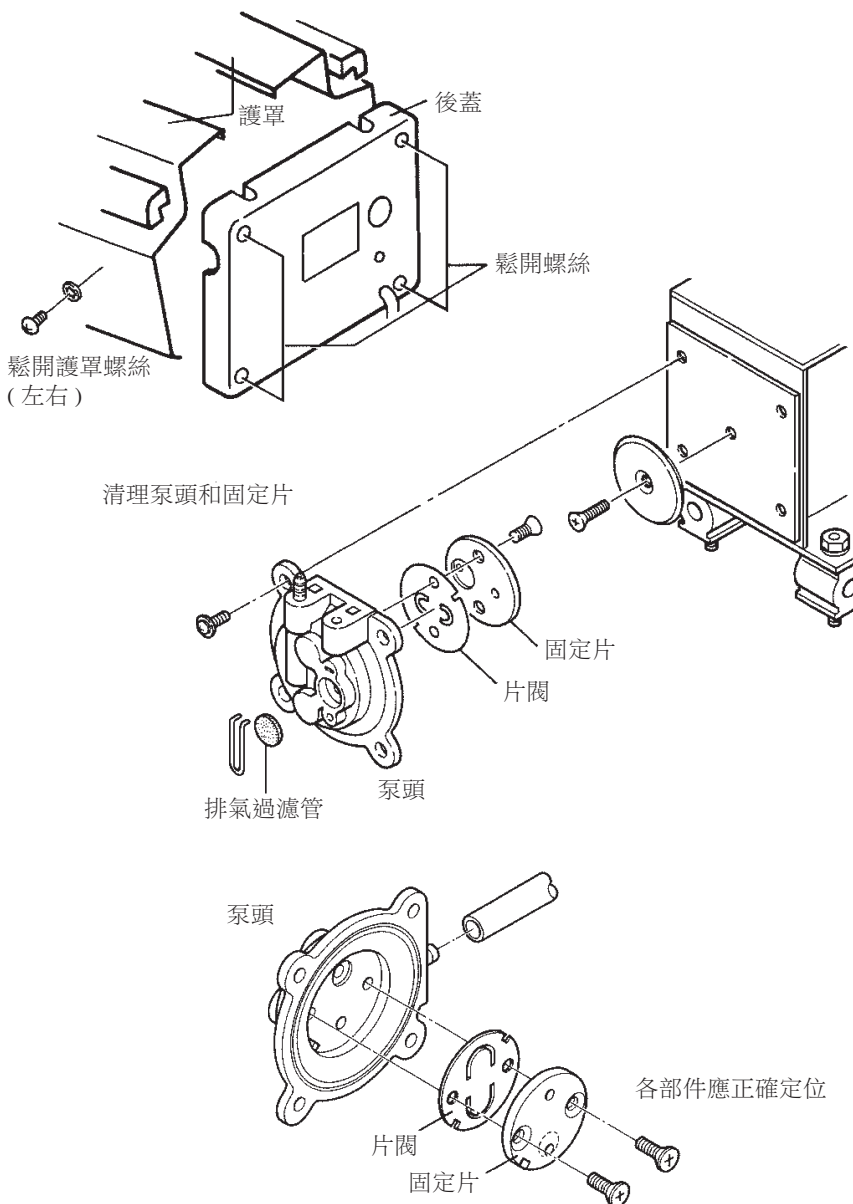

7. 更換部件

更換發熱元件

⚠警告

先拔下電源插頭，才開始更換程序。

正常發熱元件於 23°C 時，其電阻值是 2 ~ 4Ω。如果超出這個範圍，應更換發熱元件。

1 拆開發熱元件

2 打開護艙

3 拔開終端，取出發熱元件

4 置入新的發熱元件，重新回裝 (發熱元件 24V-50W)

⚠注意

在重新封合前，應確定接頭部份必須完全置入玻璃管內。

5 重新校準溫度

新的發熱元件的電阻值各不相同，致使操作溫度也各不相同。

因此，每次更換發熱元件時，都要重新校準溫度。

- 設定溫控鈕為 1，讓吸錫槍加熱 3 分鐘。
- 以焊鐵頭溫度計，調節校準計 (CAL 記號) 溫度，直到吸嘴溫度昇到 380°C 為止。

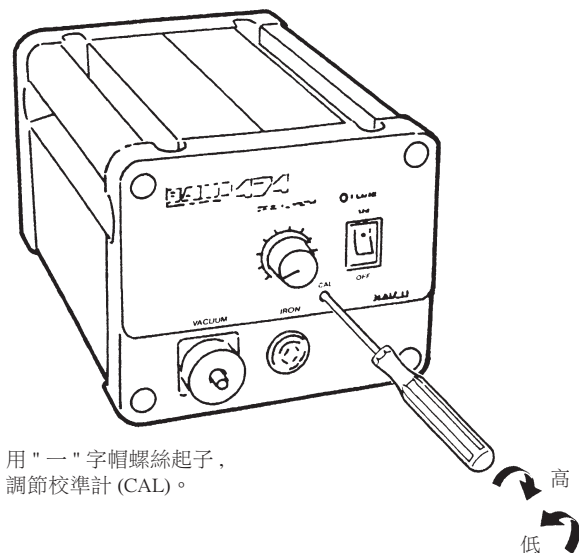
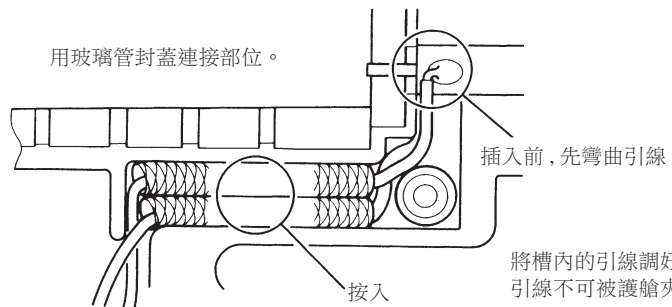
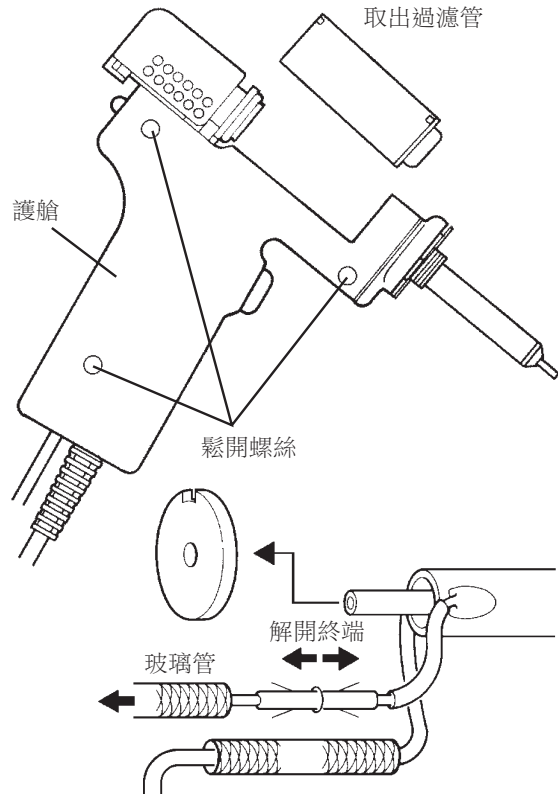
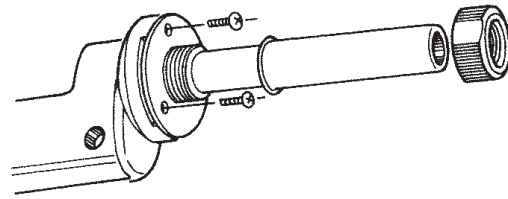

8. 部件清單 (控制臺)

註：安裝螺絲如果在說明表內沒有記載時，請另外訂購。

圖號	部件編號	部件名稱	規格
1	B1029	真空出口蓋	
2	A1009	陶瓷過濾紙 (小)	10 個
3	B1063	過濾紙護圈	
4	B1031	真空出口護圈	包括圓環 (S20)
5	B1034	圓環 (S20)	
6	B1038	控緊螺絲護罩	1 套 4 件
7	B1036	插座	
8	B1028	旋鈕	
9	B2061	前護板	
10	B1093	護罩	一邊
11	B1061	手柄	一邊
12	B1044	控溫定位螺絲夾	
13	B2057	印刷電路板	包括電位計

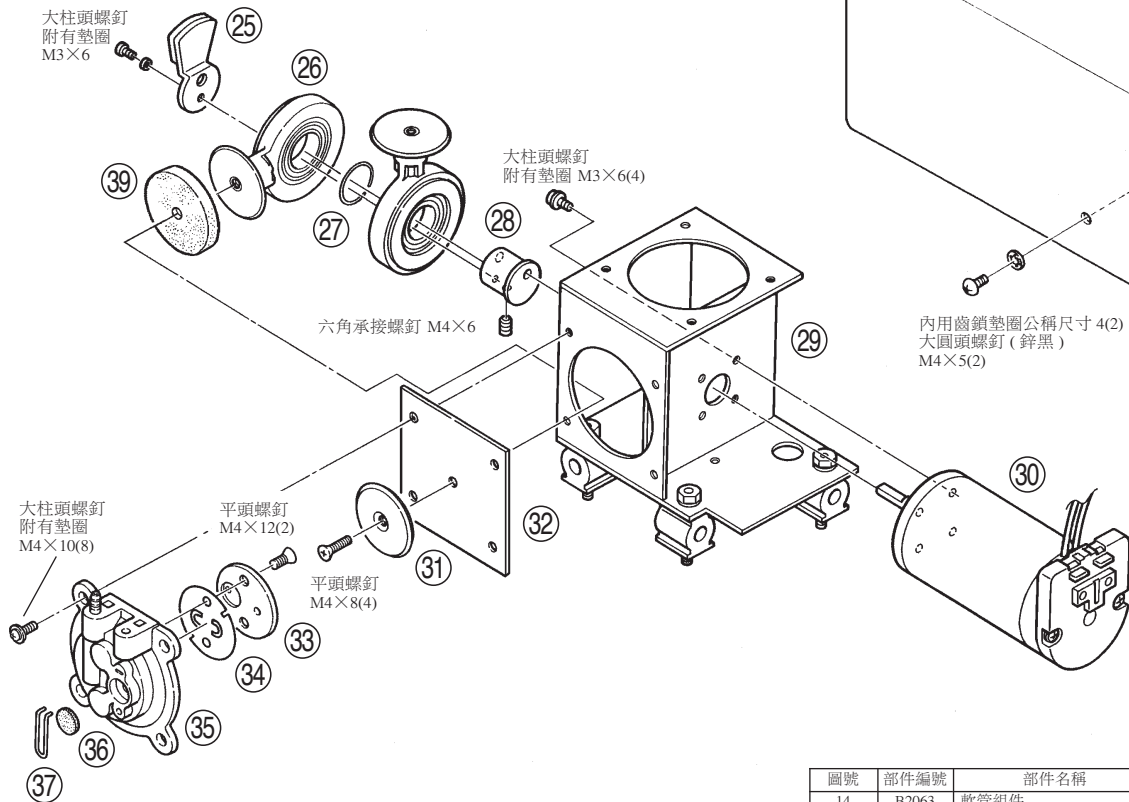
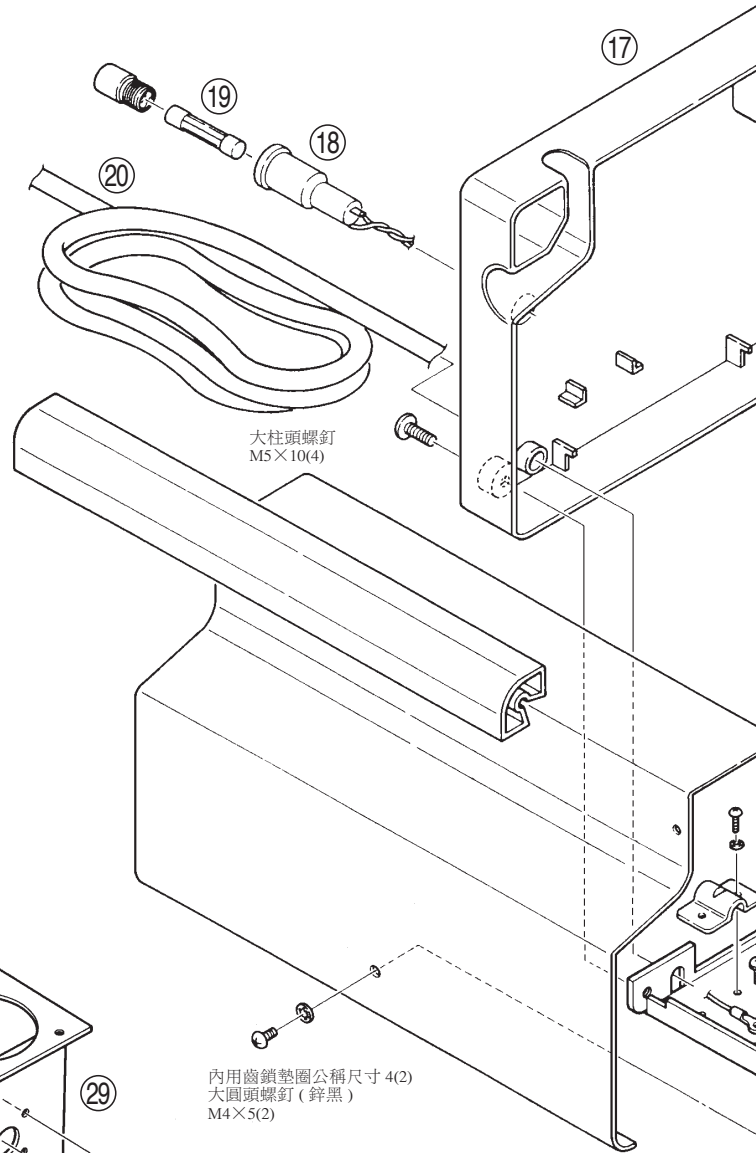

圖號	部件編號	部件名稱	規格
14	B2063	軟管組件	
15	B2065	變壓器	100-24V
	B2077	變壓器	110-24V
	B2078	變壓器	120-24V
	B2080	變壓器	220-24,230-24,240-24V
16	B2444	泵組件	
17	B2067	後護板	有等級印戳
18	B1041	保險絲套	不包括保險絲
	B1134	保險絲套	不包括澳洲 240V 保險絲
19	B1042	保險絲	125V-2A/100,110V
	B1138	保險絲	250V-1A/220,230V
	B1139	保險絲	250V-1A 澳洲 240V
	B1275	保險絲	250V-2A(U)/120V

中文

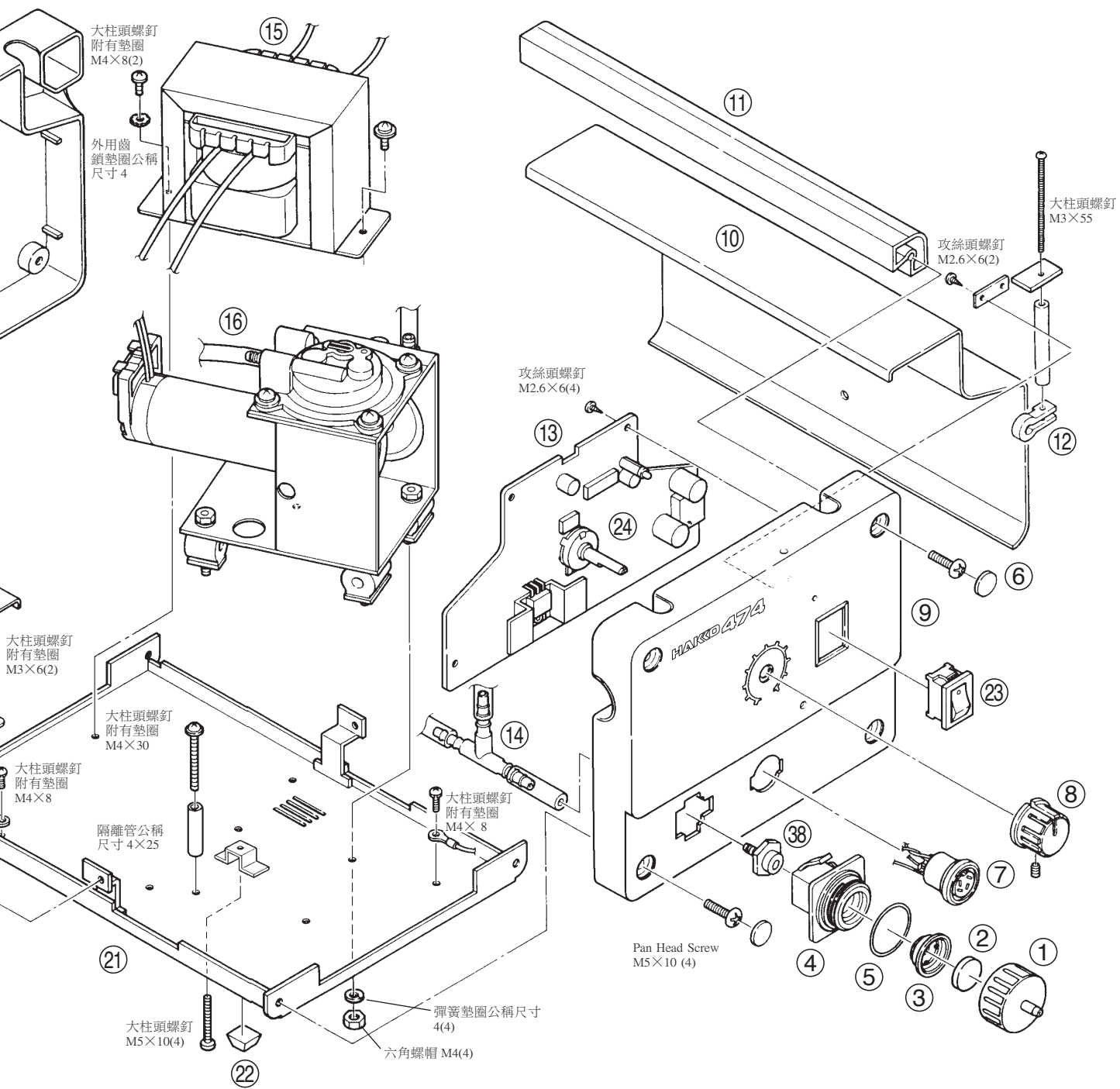

圖號	部件編號	部件名稱	規格
20	B2068	電源線三芯美式插頭	美國用
	B2079	電源線三芯無插頭	
	B2081	電源線三芯澳洲式插頭	
	B2082	電源線三芯英國式插頭	
	B2083	電源線三芯歐洲式插頭	
	B2490	電源線三芯中式插頭	
	B3505	電源線三芯美式插頭	
21	B2066	底盤	一套 4 個
22	B1037	膠塞	
23	B1084	電源開關	
24	B1078	電位計	
25	B1053	平衡錘	包括軸承
26	B1312	曲柄	

圖號	部件編號	部件名稱	規格
27	B1057	軸承圈	
28	B2060	曲柄軸	
29	B2059	泵體	
30	B2058	馬達	
31	B2085	定位片隔板	
32	A1013	隔板	一套 2 個 包括螺釘
33	B1056	固定片	
34	A1014	片閥	一套 2 個
35	B1050	泵頭	包括螺釘
36	B1059	排氣過濾管	一套 2 個
37	B1313	過濾管夾針	
38	B1064	過濾管接合套	
39	B2506	氣流調節片	一套 2 個

8. 部件清單 (吸錫槍)

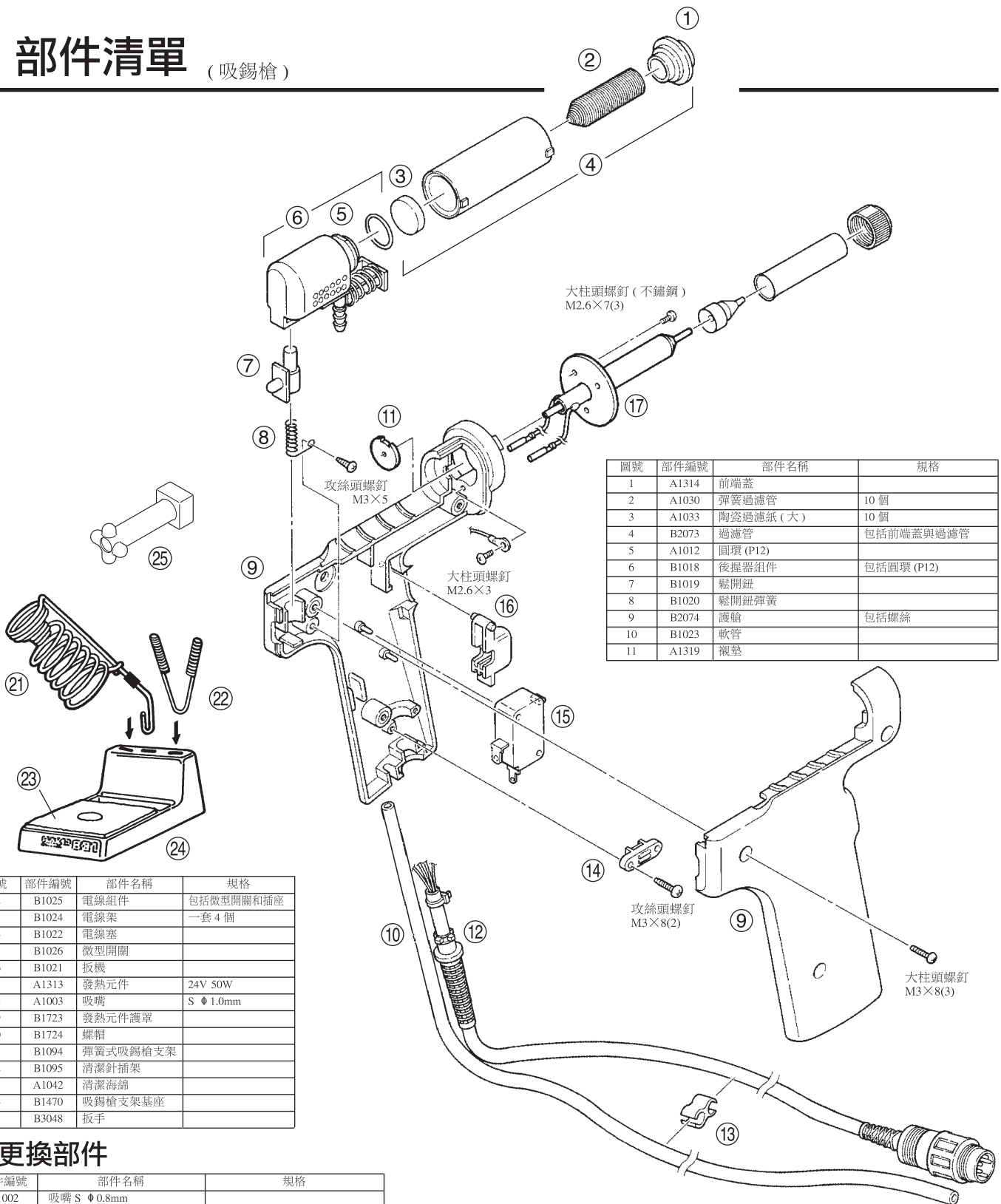

圖號	部件編號	部件名稱	規格
1	A1314	前端蓋	
2	A1030	彈簧過濾管	10 個
3	A1033	陶瓷過濾紙 (大)	10 個
4	B2073	過濾管	包括前端蓋與過濾管
5	A1012	圓環 (P12)	
6	B1018	鬆開器組件	包括圓環 (P12)
7	B1019	鬆開鈕	
8	B1020	鬆開鈕彈簧	
9	B2074	護脷	包括螺絲
10	B1023	軟管	
11	A1319	襯墊	

圖號	部件編號	部件名稱	規格
12	B1025	電線組件	包括微型開關和插座
13	B1024	電線架	一套 4 個
14	B1022	電線塞	
15	B1026	微型開關	
16	B1021	扳機	
17	A1313	發熱元件	24V 50W
18	A1003	吸嘴	S ϕ 1.0mm
19	B1723	發熱元件護罩	
20	B1724	螺帽	
21	B1094	彈簧式吸錫槍支架	
22	B1095	清潔針插架	
23	A1042	清潔海綿	
24	B1470	吸錫槍支架底座	
25	B3048	扳手	

● 更換部件

部件編號	部件名稱	規格
A1002	吸嘴 ϕ 0.8mm	
A1003	吸嘴 ϕ 1.0mm	
A1004	吸嘴 ϕ 0.8mm	
A1005	吸嘴 ϕ 1.0mm	
A1006	吸嘴 ϕ 1.3mm	
A1007	吸嘴 ϕ 1.6mm	

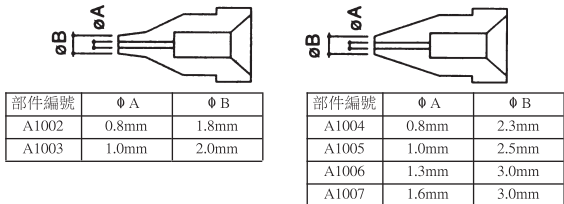

HAKKO
HAKKO CORPORATION
HEAD OFFICE
 TEL: +81-6-6561-3225 FAX: +81-6-6561-8466
<http://www.hakko.com> E-mail: sales@hakko.com

OVERSEAS AFFILIATES
U.S.A.: AMERICAN HAKKO PRODUCTS, INC.
 TEL: (661) 294-0090 FAX: (661) 294-0096
 Toll Free (800)88-HAKKO

HONG KONG: HAKKO DEVELOPMENT CO., LTD.
 TEL: 2811-5588 FAX: 2590-0217
<http://www.hakko.com.hk>
 E-mail: info@hakko.com.hk

SINGAPORE: HAKKO PRODUCTS PTE., LTD.
 TEL: 6748-2277 FAX: 6744-0033
<http://www.hakko.com.sg>
 E-mail: sales@hakko.com.sg

部件編號	部件名稱	規格
B1215	清潔針	供發熱元件用
B1086	清潔針	供 ϕ 0.8mm 吸嘴用
B1087	清潔針	供 ϕ 1.0mm 吸嘴用
B1088	清潔針	供 ϕ 1.3mm 吸嘴用
B1089	清潔針	供 ϕ 1.6mm 吸嘴用
B1302	清潔鑽	供 ϕ 0.8mm 吸嘴用
B1303	清潔鑽	供 ϕ 1.0mm 吸嘴用
B1304	清潔鑽	供 ϕ 1.3mm 吸嘴用
B1305	清潔鑽	供 ϕ 1.6mm 吸嘴用
A1028	硅脂潤滑劑	

Please access to the following address for the other Sales affiliates.
<http://www.hakko.com>
 Copyright © 2009 HAKKO Corporation. All Rights Reserved.

中文